

# CORVETTE C3 TILT & TELESCOPING COLUMN DISASSEMBLY INSTRUCTION PIC #3

## 7. REMOVE AND INSTALL SHIFT TUBE, IGNITION AND DIMMER SWITCH ASSEMBLIES

### REMOVE

1. Remove parts as shown.

### INSTALL

1. Install parts as shown.
2. Position rod in slider hole and install ignition switch. Install lower stud and tighten to 4.0 N-m.
3. Install dimmer switch and depress switch slightly to insert 3/32" drill. Force switch up to remove lash, then tighten screw, and nut to 4.0 N-m.
4. Place shifter in neutral and install shift lever.

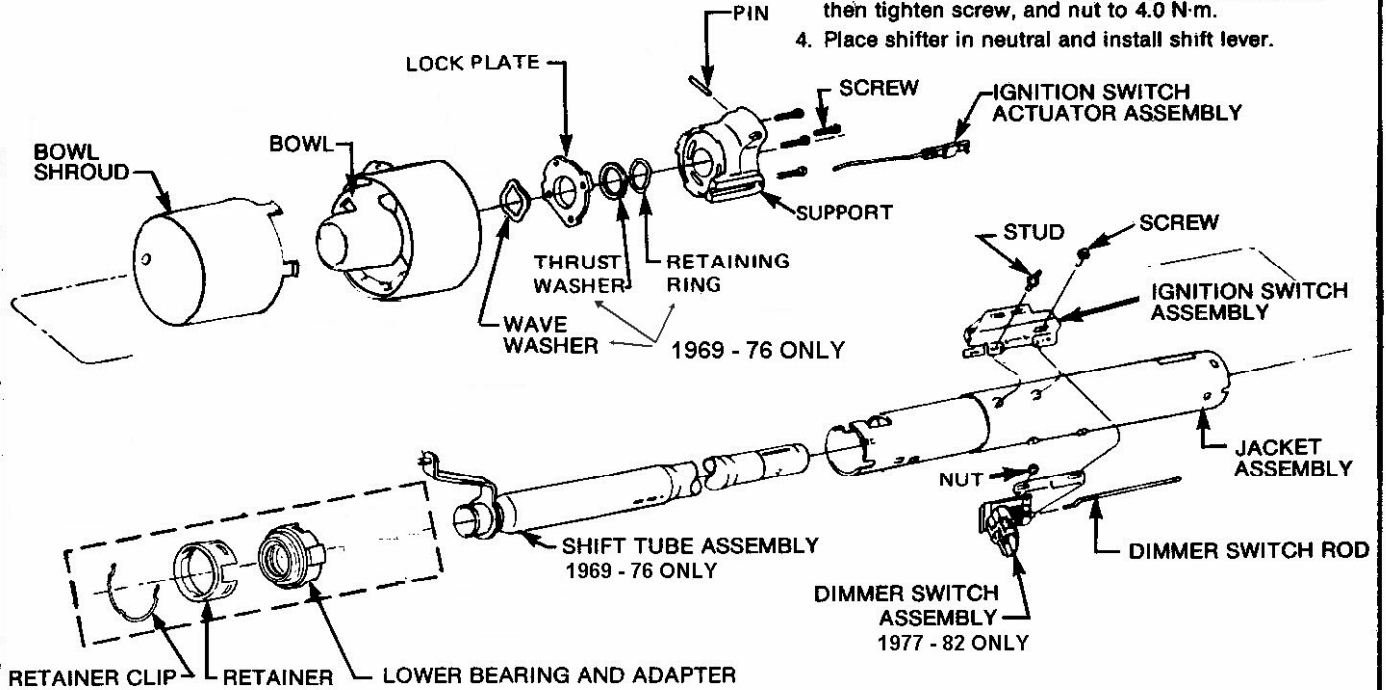

### INSTALL IGNITION SWITCH ASSEMBLY

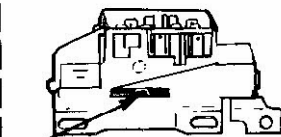

MOVE SLIDER TO EXTREME RIGHT POSITION (ACC.) THEN MOVE SLIDER TWO DETENTS TO THE LEFT TO "OFF" POSITION.

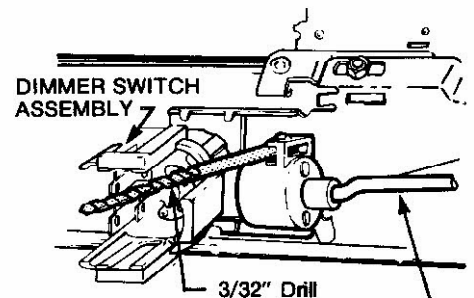

ADJUST DIMMER SWITCH ASSEMBLY

### KEY RELEASE LEVER

KEY RELEASE SPRING

1977 - 82 ONLY

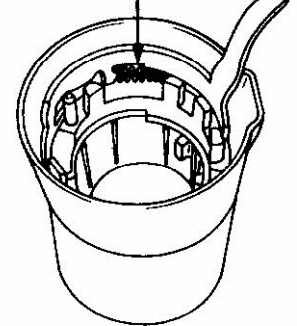

J-23072

1969 - 76 ONLY

REMOVE SHIFT TUBE ASSEMBLY FROM BOWL

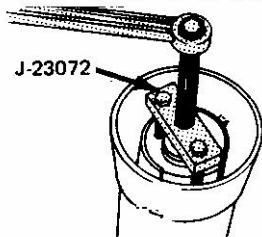

J-23073

INSTALL SHIFT TUBE ASSEMBLY

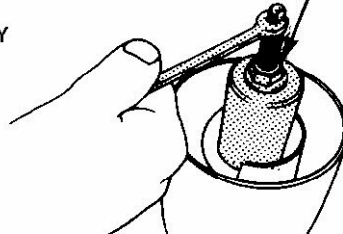

KEY RELEASE LEVER