

CORVETTE C3 TILT & TELESCOPING COLUMN DISASSEMBLY INSTRUCTION PIC #1

1. REMOVE AND INSTALL SHAFT LOCK AND/OR CANCELLING CAM

REMOVE

1. Remove parts as shown.

INSTALL

1. Install parts as shown.

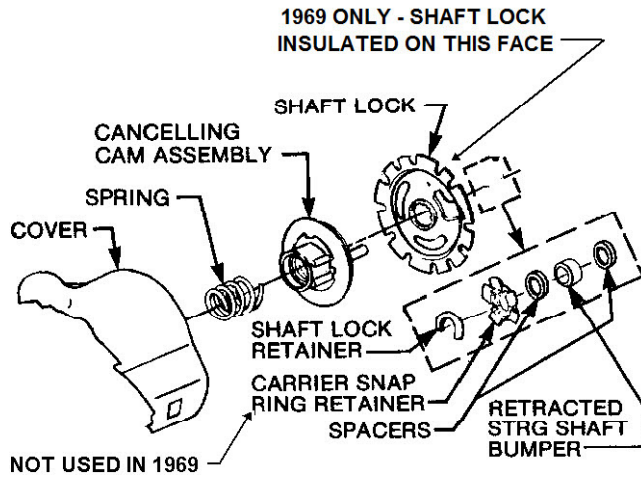

* DIMMER COLUMN ONLY

+ 1979 THRU 82 COLUMNS

1969 THRU 76 COLUMNS

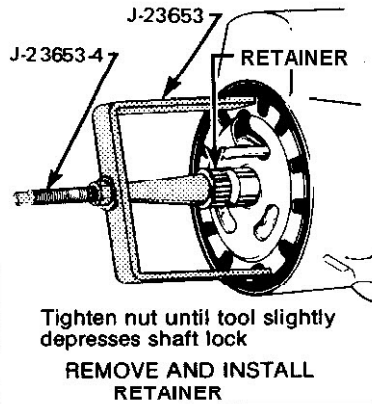

2. REMOVE AND INSTALL TURN SIGNAL SWITCH

REMOVE

1. Remove parts as shown.

INSTALL

1. Install parts as shown.

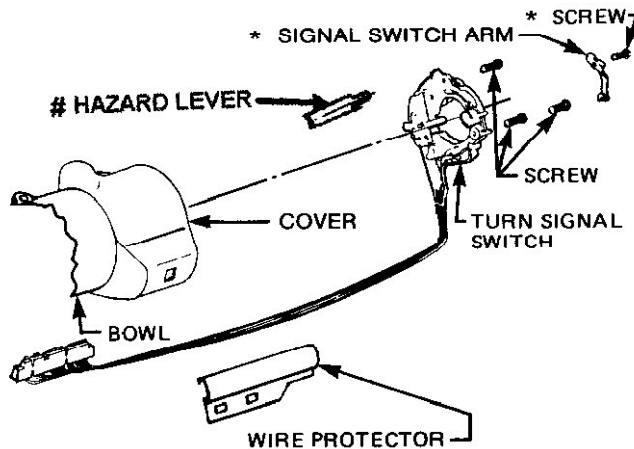

3. REMOVE AND INSTALL IGNITION LOCK AND KEY WARNING BUZZER

REMOVE

1. Turn lock to "RUN" position and remove key warning buzzer.
2. Remove parts as shown.

INSTALL

1. Install lock cylinder.
2. Turn lock to "RUN" position and install key warning buzzer switch.

To assemble, rotate to stop while holding cylinder.

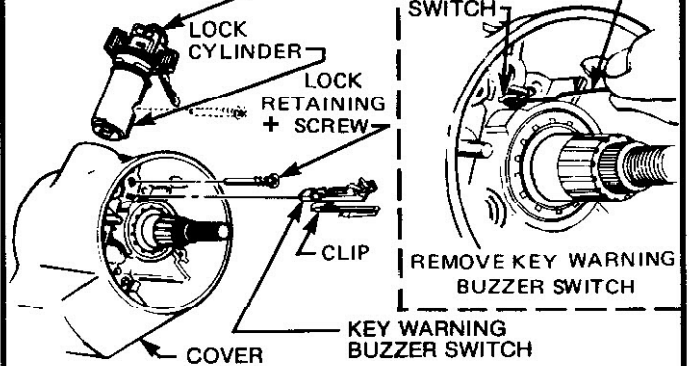

4. REMOVE AND INSTALL COVER AND WIPER SWITCH

REMOVE

1. Remove parts as shown

INSTALL

1. Install parts as shown.

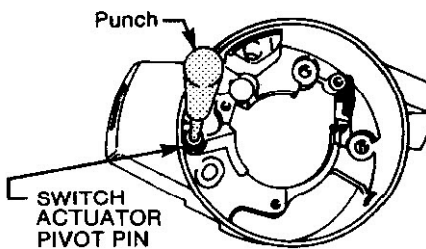
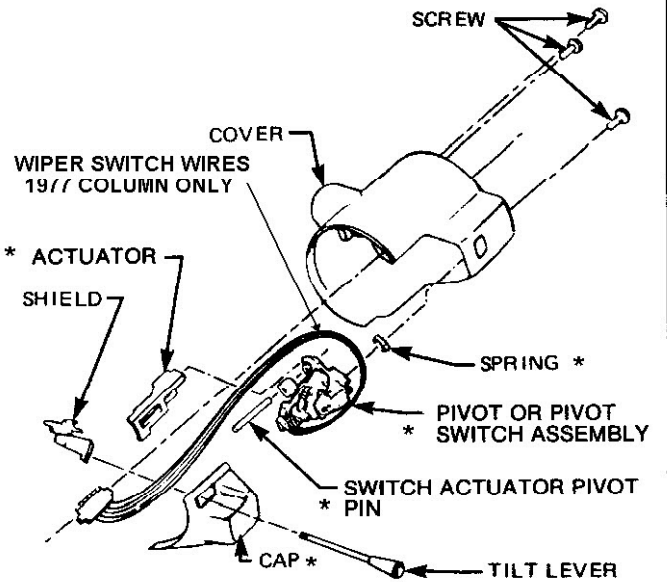

* REMOVE AND INSTALL PIVOT AND SWITCH ASSEMBLY