

GM A-CAR 1969-72 STANDARD STEERING COLUMN - PAGE 1

1. REMOVE AND INSTALL LOCK PLATE AND/OR CANCELLING CAM

REMOVE

1. Disconnect negative battery cable.
2. Refer to STEERING WHEEL - Removal.
3. Remove parts as shown.

INSTALL

1. Install parts as shown.
2. Refer to STEERING WHEEL - Installation.
3. Connect negative battery cable.

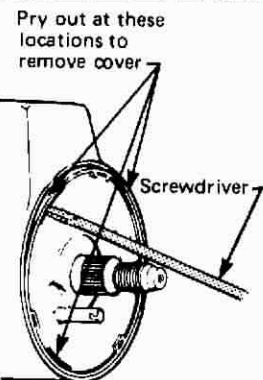
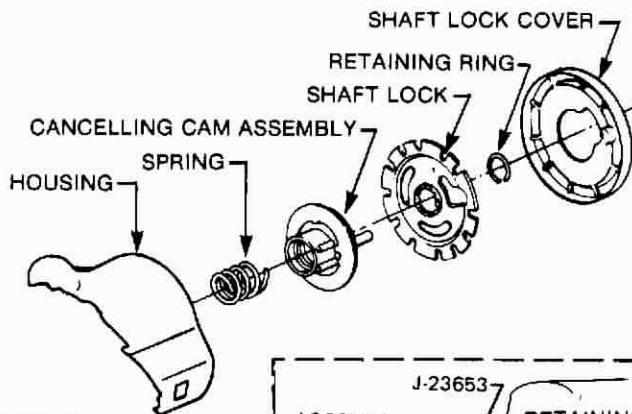

REMOVE SHAFT LOCK COVER

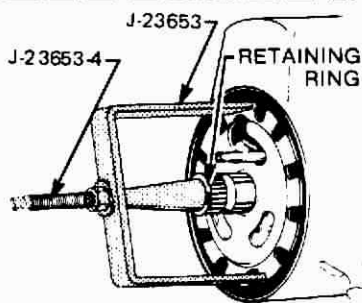

Tighten nut until tool slightly depresses shaft lock.

REMOVE AND INSTALL RETAINING RING

2. REMOVE AND INSTALL TURN SIGNAL SWITCH

REMOVE

1. Remove parts as shown.

INSTALL

1. Install parts as shown.

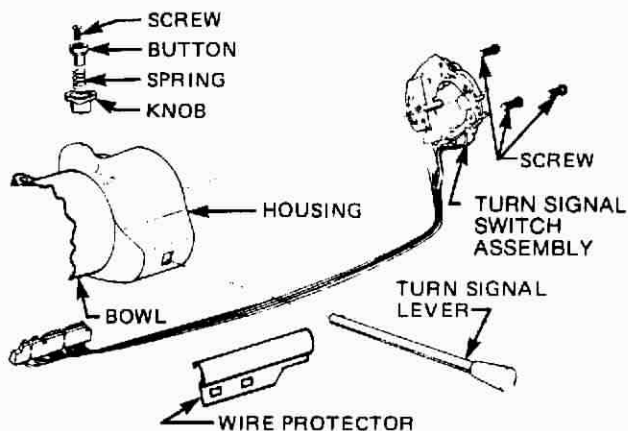

3. REMOVE AND INSTALL IGNITION LOCK AND KEY WARNING BUZZER

REMOVE

1. Turn lock to "RUN" position and remove key warning buzzer switch.
2. Remove parts as shown.

To assemble, rotate to stop while holding cylinder.

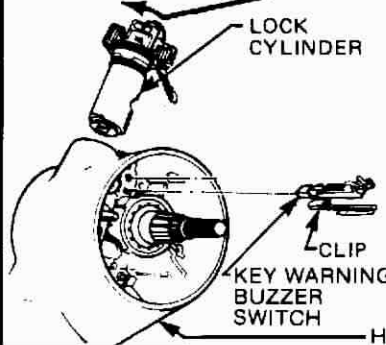

INSTALL

1. Install lock cylinder.
2. Turn lock to "RUN" position and install key warning buzzer switch.

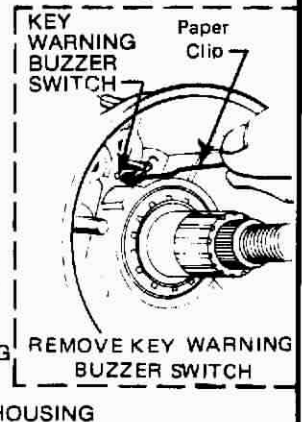

4. REMOVE AND INSTALL HOUSING

REMOVE

- Remove ignition switch.
- Refer to step 5.
- Remove parts as shown.

INSTALL

- Assemble rack so that first rack tooth engages between first and second tooth of sector.
- Install parts as shown.
- Install ignition switch.
- Refer to step 5.

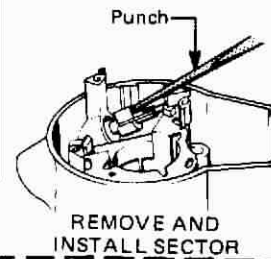
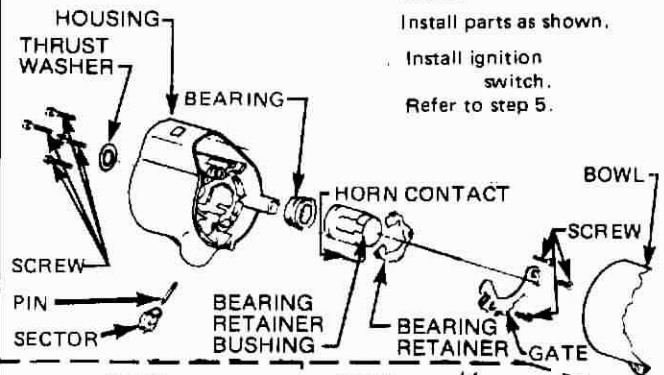

REMOVE AND INSTALL SECTOR

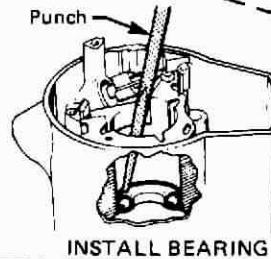

INSTALL BEARING