

INSTALLING A 2ND GENERATION F-CAR COLUMN (1970-1978) INTO A 1969 (1st GENERATION) F-CAR

Please note that these instructions are for the 1969 F-car only! The 1967-68 F-cars had a different design steering column and will not accept later steering columns. It is also recommended that you consult your 1969 F-car Service Manual for complete steering column assembly procedures and fastener torques.

The 1969 model year was the last year for the 1st generation Camaro/Firebird. Because the steering system was designed as rear steer, the steering column connected directly onto the flexible coupling that was part of the steering gear. The 1969 model was also the first year for the new, function locking, energy absorbing steering column.

The 2nd generation, F-cars also had a function locking steering column but they had a redesigned steering system where the steering gear was mounted forward in the car and a intermediate steering shaft was required to reach between the steering column and the flexible coupling on the steering gear.

Both standard (non-adjustable) and tilt F-car steering columns from these 2nd generation vehicles (1970 up through the 1978 model year) can be adapted and installed into a 1969 F-car in the following manner:

The intermediate steering shaft in the 2nd generation F-car connects by means of a clamp, nut, and bolt to a one inch diameter steering column shaft that has serrations and a notch. Note, after the 1977 model year, the connection between the intermediate steering shaft and the steering column was changed to a double flatted shaft (called a double D). So columns after 1977 will not fasten to the detachable flange and therefore will not interchange.

- 1). First of all, disconnect your car battery. Whenever you are working on the steering column it is a good idea to make sure that all electrical connections are inactive.
- 2). Disconnect and remove the bolt from the clamp and nut holding the pot coupling to the 2nd generation steering column. Remove the pot coupling and intermediate shaft from the steering column and discard them.
- 3). The original 1969 steering column has a lower floor pan bracket that was made in two pieces and is bolted together. The 1970-78 steering column has a metal floor pan bracket that is spot welded in place on the column. You will need to use the adjustable 1969 bracket in place of the later welded design. Carefully grind off the spot welds and remove the bracket from the column. Loosely assemble the two piece bracket from your original column onto your 2nd generation column.

4). The detachable lower flange is GM part number #7807052 and the pinch bolt is GM #7807271. The pinch bolt is still available from GM dealers but the flange is no longer listed as a GM service part. If you are lucky you may be able to still locate the flange on a dealer's parts shelf. The flange may still be available from various Camaro suppliers. Note that the flange is very compact and is only 0.88 inches tall. (See picture at end of this paper.) Taller flanges have been used on Corvettes and other GM tilt column applications but may space your steering column too far rearward inside your driver compartment.

5). The detachable lower flange 7807052 should easily assemble onto your 2nd generation column steering shaft. Orient the flange to the column shaft so that the pinch bolt passes easily right through the notch. Torque the pinch bolt to 25-30 ft-lbs.

6). Attach the electrical connectors and loosely assemble the steering column into the car. Remember, if you are going from a standard to a tilt steering column, you must rotate the body harness electrical connectors 180 degrees where they assemble to the ignition switch.

Some people have reported that turn signal switches in the later steering columns have a "harmonica" connector that will not snap into the original vehicle harness. (They look very similar but they just won't connect.) So make sure that you try to connect the turn signal harmonica connector to the vehicle harness as well. If the new switch connector easily snaps into place you are good to go. However, if the connector will not assemble, you will want to swap the harmonica connector from the old column onto the switch wires in the later column.

Here is the swap procedure; disengage and remove the individual switch wires and metal contacts from both plastic harmonica connectors. Straighten a heavy paper clip and insert it into the harmonica connector from the contact side to disengage each wire and contact. There should be a small molded square channel in the connector that will guide you to a metal tang on the contact that holds it in place. Once you depress the tang and pop the wire and contact out of the connector, you should take a small knife blade and bend the tang back out so that it will engage the old connector correctly

You must make careful note of the exact order of the wires in the connector so that when you reassemble them, all your lights, horn, and buzzers will work correctly.

7). Attach the column flange to the flexible coupling on the steering gear. You should be able to reuse the nuts and lock washers from your original connection to attach the flange. The nuts have 5/16-24 UNF and 3/8-24 UNF threads. Torque both nuts to 20 ft-lbs.

8). Loosely assemble the steering column into the car. With a column shift connect the PRNDL wire to the column. Attach the shifter linkage or the back drive rod to the column lower lever.

9). It is very important that the steering column be assembled into the car so that it is aligned correctly to the steering gear. Also, the steering column alignment procedures and fastener tightening should be performed with the car sitting with its weight on the road wheels.

The following is a brief summary of the steering column alignment procedures. Please consult your 1969 F-car Service Manual for a more complete description.

- a). With the column in place and the fasteners snug, inspect the flexible coupling. Both flexible coupling stop pins should be extending through the column flange windows by at least 0.25 inch. The rubber coupling disc should be flat. If it is distorted, you will have to adjust the position of the steering column forward or back so that the coupling disc is flat.
 - b). Inspect and determine that the flexible coupling stop pins are central in the column flange windows. Next turn the steering wheel a quarter turn (90 degrees). Inspect both pins again, they must be central in the flange windows in this position as well. If they are not central, you will need move the lower end of the steering column, readjust the toe plate, and snug the fasteners.
 - c). When the coupling disc is flat and the stop pins are central in all positions, first torque the nuts on the vertical studs that hold the upper column. Then tighten the toe plate lower fasteners to their proper torques (consult your GM or other approved shop manuals for the proper torques and fastening sequences).
- 9). Assemble your steering wheel and column levers to the steering column. Reattach your battery.

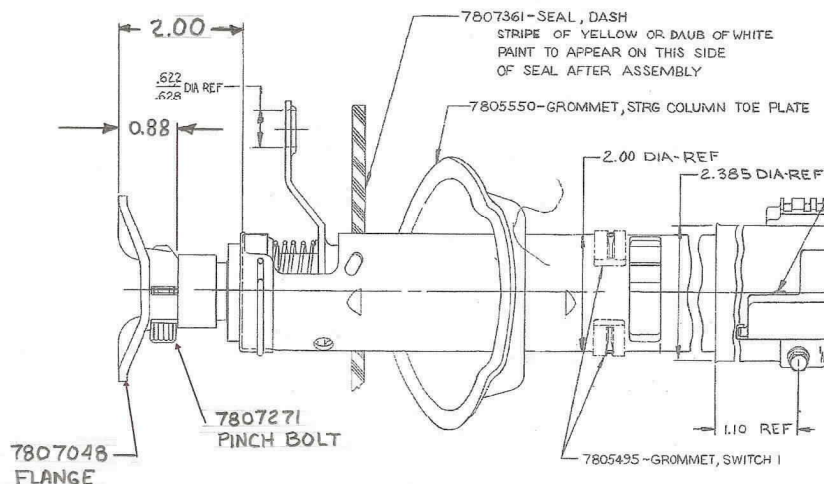

1969 F-CAR STEERING SHAFT FLANGE