

1969 THROUGH 1982 CORVETTE TILT & TELESCOPING STEERING COLUMN DISASSEMBLY & REPAIR INSTRUCTIONS PAPER #3

Disassembly and Repair Instructions Addressed in this Paper

	Degree of Difficulty	Page
REPLACE THE WASH/WIPE SWITCH (1977 ONLY)	Difficult	2
DIMMER PIVOTS AND TURN SIGNAL LEVERS (1978 THROUGH 1982)	Difficult	2 & 3
REPAIR & REMOVE LOOSE PIVOT PINS	Hardest	3, 4, & 5
REPAIR LOOSE LOCK SHOES	Hardest	5
REPAIR RACK AND SECTOR	Hardest	6
REPAIR THE UPPER BEARINGS	Hardest	6 & 7
REMOVING STEERING SHAFT FROM STRG COLUMN	Hardest	7
ELIMINATE LASH IN THE PLASTIC TILT JOINT	Hardest	7 & 8
STEERING SHAFT LENGTH CHECK	Hardest	8
REMOVE & INSTALL SHIFT TUBE FROM BOWL	Hardest	9
TIGHTEN SUPPORT SCREWS	Hardest	10

How the Paper is Setup

This is the third of a series of three papers that address various replacement and adjustment procedures that can be performed on the Corvette C3 tilt and telescoping (T&T) steering column.

This paper starts at the point where the steering column has been removed from the car. Also, the steering wheel, horn parts, shaft lock, ignition lock cylinder, key warning buzzer, turn signal, ignition, and dimmer switches have been removed from the T&T steering column. All of these operations were described in detail in Papers #1 & #2.

This paper makes reference to three pages of line drawings. They are entitled Corvette C3 Tilt & Telescoping Steering Column Disassembly Instruction Pic #1, #2 & #3.

There is a schematic drawing entitled 1969-76 Corvette Tilt & Telescoping Column Blowup. There is also another schematic entitled Tilt Steering Column w/Key Release & Dimmer (similar to 77-82) Blowup Pic. This drawing does not show the telescoping upper shaft but it does show the dimmer and key release parts. For the most part I will use the callouts from the 1969-76 blowup.

The drawings are all available from the author or from the host websight. You will find these pictures and descriptions to be most helpful when working on your steering column.

The T&T steering columns from 1969 through 1976 are called “round” columns because the column head is completely circular in shape. Starting in 1977, a characteristic bulge appeared on the left side of the column head. This bulge housed the headlight dimmer pivot which actuated a rod which tripped the dimmer switch now mounted on the steering column jacket down under the dash.

Turn Signal Levers

The 1969 through 1976 turn signal lever screwed into a metal post inside the steering column head. The 1977 through 1982 turn signal lever has a metal end that "plugs into" the plastic (or die cast) dimmer pivot. The lever is held in place with a spring loaded ball that is part of the pivot. You should be able to push/pull directly on the lever to assemble or disassemble it from the pivot.

Disassemble the Column Head - Shown On Instruction Pic #1

Remove the tilt and turn signal levers. Remove the three turn signal housing screws #12 located at the 12, 3, and 8 o'clock positions .

On 1977 and later columns the turn signal housing #15 will also contain a dimmer pivot assembly, a wash/wipe switch (1977 only) and a dimmer rod actuator which will come with the housing and its end cap. Be careful of the end cap and dimmer switch rod actuator. Separate the actuator from the cap by simply pulling them apart. They are held together by grease.

Guide the (1977) wash/wipe wires out of the column as you remove the cover. It is a good idea to tie tracer string to the wiring connector to aid when you reassemble it.

1977 Dimmer Pivot with Wash/Wipe Switch

The 1977 steering column had the dimmer, turn signal, and windshield wash/wipe all integrated into the turn signal lever. This was a one year only system and the dimmer pivot with integral wash/wipe switch was shared with the Chevette. The pivot is held to the inside of the cover by a press fit pivot pin. You must feed the wash/wipe switch wires back through the cover. Then use a punch to remove the pin. The switch/pivot can be pulled from the cover. The 1977 wash/wipe switch/dimmer pivot is GM #7827252 but it is no longer available through GM dealers. The turn signal/wash wipe lever is Doc Rebuild 2897112.

1978-82 Dimmer Pivots & Turn Signal Levers

Starting in 1978 the C3 wash/wipe switch was returned to the instrument panel. So the pivot was simplified. However, from 1978 through 1982 there were three different combinations of dimmer pivots and turn signal levers. For some years (particularly 1978-79) you are going to need to determine which vintage dimmer pivot that you have.

1978 SOP had a dimmer pivot (Corvette Central #563002) that was held in place in the turn signal housing by means of a big screw and the turn signal lever mounting hole in the pivot was at a shallow 21 degrees.

1978 Late to 1979 - The attachment of the dimmer pivot was changed from a screw to a pressed-in pin (Corvette Central dimmer pivot #563001). So you will need to know if your housing is threaded for the screw or does it have a hole for the pressed-in pin. I do not have any information as to how "early" or "late" in the model year the change occurred. The turn signal lever hole in the pivot remained at 21 degrees.

Dimmer Pivots & Turn Signal Levers (Continued)

The 78 to 79 - The turn signal lever w/cruise (GM 25030522, ZIP SC-337 or Doc Rebuild #2897116) had a 30 degree bend in it because the dimmer pivot had the lever mounting hole that was at a shallow angle (21 degrees) and the lever needs to bend toward the steering wheel rim such that the driver can easily reach the cruise button.

The 78-82 T&T turn signal lever w/o cruise was GM 14009242, ZIP SC-333 or Doc Rebuild #2897118. It was a straight lever.

The next change occurred late in the 1979 model year. The angle of the turn signal lever mounting hole in the dimmer pivot was changed to 46 degrees. The turn signal lever now was pointed more directly at the steering wheel and the turn signal lever was straight. Zip Products lists a 79L-82 Turn Signal Arm Pivot Assembly SC-756. This should be the pivot that works with straight turn signal levers.

Here are the T&T levers that I think work with the 46 degree pivot. GM 25030492, Zip Products 79L-80 Turn Signal Lever w/tele & w/o cruise SC-332. 1981-82 Turn Signal Lever w/cruise (Resume Switch on side of lever) Doc Rebuild 289119.

Remove Tilt Spring - Shown On Instruction Pic #2

Replace the tilt lever and place the column in the full “up” position.

Caution: The spring is quite powerful, without the steering wheel to counterbalance its force, the column head can spring upward with a lot of energy.

Remove the tilt lever spring retainer #16 using a tool that just fits into the slot opening. Note, the picture on page #6 shows a screwdriver blade being inserted into the retainer slot for removal/installation. Early retainers have a slot, later retainers have a square hole. A medium size Phillips bit will fit the square shape quite well.

Caution: The spring is compressed with a lot of force. Press squarely on the retainer and press in approximately 3/16 inch, turn 1/8 turn counterclockwise until the ears align with the grooves in the housing and remove the retainer, spring #17, and guide #18.

Remove Dimmer and/or Ignition Switch – Shown On Instruction Pic #3

The dimmer switch and/or the ignition switch should already have been removed from the steering column jacket. Reference Paper #2; pages 4, 5, & 6.

Remove Pivot Pin - Shown On Instruction Pic #2

Remove the two pivot pins #35. Each of the pins has a tapped hole so that you can use the GM tool or jury rig a puller using an 8-32 screw, nut, washer, and a ½ inch or a 12mm socket. Bridge each pin with the socket and use the screw and nut to pull them out. You will note that the bowl of the transmission control lock tube housing #58 comes right up to the edge of each pivot pin. You cannot react against the fragile bowl. But you also must keep your removal tool square to the pivot pins. Two home made tools that provide clearance to the bowl and keep things square are shown on the next page.

TILT OR T&T STEERING COLUMN PIVOT PIN PULLER TOOLS

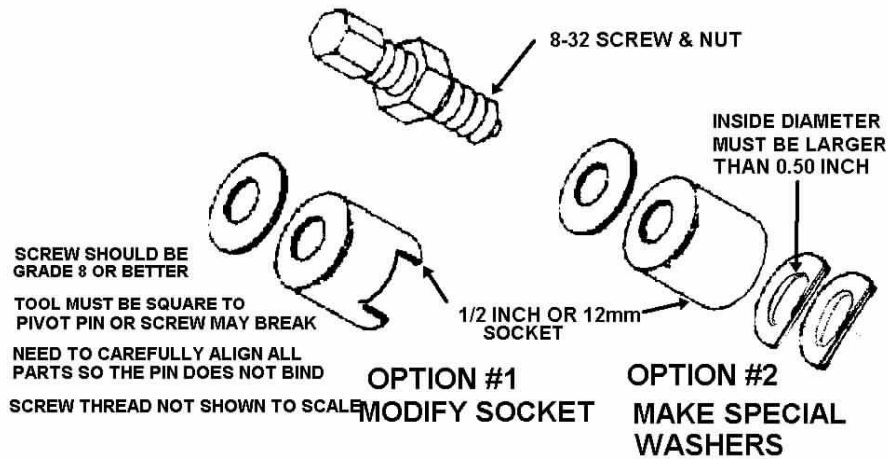

Another method to extract the pivot pins would be to thread a 8-32 screw into the end of each pin. Grip the screw with a slam puller tool. A few quick raps should draw the pin right out. Using that same 8-32 screw you can try prying the pin out of the bearing housing using the claw end of a hammer (protecting the column parts with a piece of wood where you leverage the hammer.)

Remove Bearing Housing – Shown On Instruction Pic #2

Remove the housing by pulling upward on the tilt lever and pull the housing upward until it stops. Move the housing to the right or left to disengage the rack #37 from the ignition switch rod #38. Pull the housing up off the steering shaft assy.

Loose Pivot Pins

You should be able insert the smaller diameter of the pivot pin #35 into the hole in the support #49. Now, thread an 8-32 screw all the way into the tapped hole in the pivot pin. Secure it in place with a jam nut. Now, try and wiggle the screw, you should not feel any motion between the pivot pin and the support. If one or both holes in the support are badly out of round or tapered, it is probably best to replace the support.

If there is any detectable play at the pivot pin to support or at the pivot pin to housing interface, you will feel play in the steering column head in the side to side direction.

The pivot pin large diameter (0.4000/0.4005 inch) should be a press fit to the bearing housing #24. It should be impossible for you to insert it into the housing by hand. The pin smaller diameter (0.3745/0.3740 inch) should be a sliding fit to the support #49. The pivot pin holes in the support and in the housing as well as the diameters of the pivot pins are held to very precise tolerances.

You will have to tap the pins with a hammer or press them in place with a c-clamp or other device. Once a pin is pressed in place in the housing, it should be secure with absolutely no looseness.

Loose Pivot Pins – Possible Corrective Actions

- 1). The pivot pins are hardened. They also have a very thin surface coating. The first thing to try is to rotate the loose pivot pin(s). It just might be possible that the surface coating on the pin may be worn in just one location so that rotating the pin to a different position and reinserting into the housing or support might regain the precision fit.

- 2). The next approach may be to replace the housing or support with one that has pivot holes of the correct size. The support #49 from any tilt or T&T column from 1969 through at least 1982 should be an acceptable replacement. However, only a T&T column with a round head can supply the housing #24 for a 1969 through 76 T&T column. Only a T&T dimmer column (one with the bulge on the left side of the housing) can supply a replacement housing for a 1977 through 1982 column. T&T columns were also available in Cadillacs and big Oldsmobiles from 1969 through the 1970s.

- 3). The other course of action is to make the pivot pins larger. If you have access to a machine shop, you could fabricate new pivot pins from hardenable steel with a larger outside diameter to regain the press fit to the housing and/or the precision slip fit to the support. Another thing you could try is to plate the original pivot pins. After plating you will probably have to polish the appropriate diameters so as to attain the proper interference or slip fit. Remember, a press fit is only a few ten thousandths of an inch of interference between the pins and the housing holes. Any more interference and the pins will plow metal out of the mating housing holes as they are being inserted rather than just expanding the hole to lock them in place.

Loose Lock Shoes

There are two lock shoes #25 in every tilt or T&T steering column. They alternate locking the steering column tilt head one at a time. The Corvette T&T column has one shoe with four engagement slots while the other shoe has three slots. This results in seven tilt positions in a Saginaw adjustable steering column. That is why if you have one bad shoe or the pin is worn where only one shoe pivots, it is possible that your column head may feel loose at every other tilt position.

Both shoes pivot on a small pin #27 that is part of the housing. They engage a pin #50 that is part of the support.

Look for a worn shoe pivot pin. The shoes should rotate freely on the pin but there should be no noticeable looseness. Replace the pin and/or the shoes if needed. **DO NOT LUBRICATE THE SLOTS IN THE LOCK SHOES.** They should be “dry as a bone”. It is possible that the column can be made to “ratchet” all the way to the lowest tilt position if the slots are lubricated.

If you have access to a donor tilt or T&T steering column, you may find that the lock shoes do not have locking slots in exactly the same location as the shoes from your Corvette T&T. The Corvette column had the maximum amount of tilt adjustment travel of any of the GM columns. Tilt shoes from other adjustable columns will still fit your housing but may slightly restrict your maximum up or down tilt travel.

Remove Rack and Sector – Shown On Instruction Pic #2

Remove the tilt lever opening shield #20 from the housing and also the turn signal lever opening shield if so equipped. Remove the lock bolt spring #23 by removing the spring retaining screw #32, and moving the spring clockwise to remove the lock bolt #22.

If there is a snap ring #33, remove it from the sector drive shaft #26. With a small punch lightly tap the drive shaft from the sector. Remove the drive shaft. Remove the rack and rack spring (also a shim, if there is one). Remove sector and bolt.

Replace the Upper Bearings – Missing Balls/Broken Separator - Instruction Pic #2

There are two bearings (#21 & #39) located in the bearing housing #24, they are seated back to back with one inch between them. They consist of an outer race, a plastic ball separator, and ball bearings. The bearing outer races are press fit into the housing, one toward the driver and the other one in the other side of the housing pointed in the opposite direction. The balls ride on inner races. One is permanently pressed onto the steering shaft yoke #44. The other inner race #10, the one closest to the driver, is a loose fit to the shaft. This one is preloaded by upper bearing inner race seat #9 that is pushed by a 100 lb spring #5, and secured with that shaft lock retainer c-clip #2.

The column upper bearing service kit is GM part number 26001827. It contains one bearing with an inner and outer race.

However, if you need both bearings, I have found that it is cheaper if you purchase GM kit #7844651. The kit contains two bearings, along with a rack, sector, lock bolt spring, and screw. Just save the extra parts or replace your thirty year old rack, sector, and spring while you have the housing apart. You should be able to purchase either kit from any GM dealer.

One other suggestion. One enthusiast found very similar bearings at a bicycle shop! I would guess that they were probably a lot cheaper than going through a dealership.

Now that you have the housing removed from the column, place it on a terry cloth surface. You now need to take a small screwdriver and pop the individual ball bearings out of the separator. You will soon understand why I recommended a terry cloth work surface. With all of the balls removed, it is now possible to inspect the plastic separator. If it is brittle and broken, replace it by reaching into the housing and popping the separator out of the outer race. If it is in good condition, leave it alone.

Inspect the outer race. If it is in good condition, leave it alone. Otherwise, you need to reach through the back side of the housing with a thin punch and using the notches that are in the housing bore to assist you, work the race out of the housing. Press the new outer race into place. **Caution:** Do not press the race into the housing by pushing on the balls, this will cause them to damage the race and rotation of the steering shaft will feel rough. Snap the new separator into the outer race. Individually snap the ball bearings into the separator. Make sure that you lubricate the bearing with the grease that comes in the service kit.

Replace the Upper Bearings – (Continued)

Caution: When you purchase replacement upper bearings you should receive the balls, a plastic separator, and the outer race as a set. It has come to my attention that the replacement bearing separator may rub on the original outer race that is pressed into the bearing housing. This will cause objectionable friction when turning the steering shaft. Snap the ball bearings into the new separator and make a trial fit to the outer race in the bearing housing. Check if the new plastic carrier rubs or not. If it rubs you will need to replace the outer race with the one supplied in the kit. Follow the instructions in the previous paragraph to remove and replace the outer race.

Removing Steering Shaft from Steering Column

At this point it should be fairly easy to remove the steering shaft from the steering column. First remove the detachable flange from the lower end of the steering column shaft. With the bearing housing removed the steering shaft should slide right up and out.

However, corrosion can cause this simple procedure to be quite a bit more difficult. The lower steering column bearing and the lower steering column shaft can be exposed to road contamination and moisture. The inner race of the lower bearing assembly is a slip fit over the lower steering shaft and this race can fuse to the shaft with rust. Therefore, you may need to soak the bearing race and shaft with a penetrant. In some cases the corrosion can be so bad as to require that you slit the bearing race with a Dremel tool.

Steering Shaft Tilt Joint Lash Check & Lash Elimination Procedure

If you have removed the steering shaft assembly from the column, here is a quick test to determine if the plastic sphere tilt joint is properly snug. Straighten the shaft assembly at the pivot ball and hold the lower steering shaft as the upper steering shaft sticks straight out. There should be sufficient friction in the plastic ball to the shaft yokes so that the upper shaft will remain straight or will just barely slump downward. If the joint is so loose that the upper shaft falls to a 90 degree angle, most likely you will have some looseness in the joint where you might detect some steering wheel play while driving.

To regain the proper amount of tightness you will need to separate the upper from the lower steering shaft. First mark the upper and lower shafts so that you can reassemble them with the correct upper to lower shaft orientation.

Separate the upper from the lower shaft by bending the upper shaft at a 90 degree angle to the lower shaft. You will now be able to pull them apart. The plastic sphere will remain in the yoke of the upper shaft. Rotate the sphere 90 degrees and it will slip out of the yoke. Note that there is a preload spring in between the two spheres.

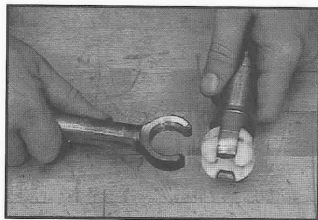

Separating Upper and Lower Shaft Sections

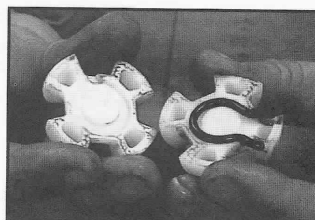

Joint Preload Spring in Centering Sphere

Lash Elimination Procedure (Continued)

Now take a mallet and tap on the lower shaft yoke ears. Do not tap on them too hard! Reassemble and try the “slump test” again. Continue tapping on the yoke ears until the looseness in the ball joint is eliminated.

You can reassemble the shafts by first installing the spring in between the two spheres. Slide and rotate the spheres into the upper yoke. Position the lower shaft onto the upper yoke and rotate the lower shaft 90 degrees, making sure that the upper shaft and the lower shaft are oriented correctly.

Steering Shaft Orientation - Reassembly Tip

Notice: If for some reason you lose the original orientation of the steering shaft yoke #44 to the lower shaft #47, you will find that you will have two possible ways to reassemble this connection. If you look closely at the steering shaft yoke, you will note that the end that points at the steering wheel has two machined flats, one on each side. However, one flat is longer than the other. This is important because the carrier #4 has a flat that must mate with the long flat. The carrier also has the turn signal cancelling tabs molded into it.

If you reassemble the shaft yoke to the plastic spheres in the wrong orientation, your turn signals will not cancel properly. (You probably won't notice this problem until you have the column back in the car!)

Here is the key to the correct alignment. Look down the steering shaft from the steering wheel end. Place the pinch bolt notch (located on the very lower end of the steering shaft, where the steering column flange is connected) at the 12 o'clock position. Now when the upper steering shaft is connected to the plastic tilt centering spheres, the short flat should also be at the 12 o'clock position.

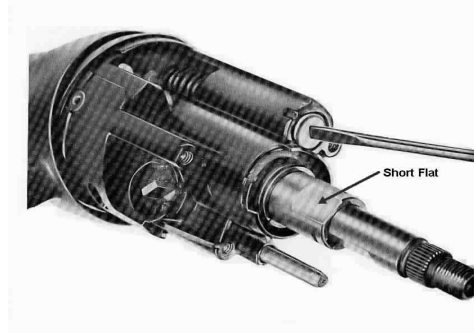

Steering Shaft Length Check

It is a good idea to check the length of the lower steering shaft #47. There are two dimensions that can be checked; one while it is out of the column, the other when it is assembled into the column. It is possible that the shaft could be compressed during handling or when the steering column was removed from the car. The lengths for the complete shaft are from the center of the yoke to the end of the shaft. If there is a question as to exactly where the yoke center might be located, place one half of the plastic centering sphere #46 in the yoke and measure from the flat surface.

Lower Shaft to Tilt Center

1969 through 1976 31.0 inches
1977 through 1982 30.1 inches

Shaft Extending out from Column Lower Brg

1968 2.21 inches to edge of clamp
1969 through 1976 4.70 inches to brg retainer face
1977 and 1978 4.90 inches to brg retainer face
1979 through 1982 5.00 inches to brg retainer face

(1969-76) Remove Bowl from Shift Tube

The shift tube #66 has a retaining ring #53 and support washer #54 that secures the lock plate #55 in place inside the mast jacket #63. Remove the ring and washer and disengage the lock plate from the mast jacket. You will find that the shift tube is a press fit into a boss that is part of the shift tube bowl #58. **BE CAREFUL!** The shift tube is designed to collapse and is quite fragile because the two telescoping shift tube segments are held together with injected plastic.



The Chevrolet Chassis Service Manual and my Corvette T&T Column Disassembly Instruction Pic #3 shows a special tool (J-23072) being used to separate the bowl from the shift tube. They also show special tool (J-23073) to reattach the two parts. These tools are hard to find and very expensive.

On the left is a picture supplied by a Corvette owner who rigged a rather large three jaw puller to separate them. Make sure that the socket or bushing that is being used to press on the shift tube end will clear the boss in the bowl.

Basic Order to Reassemble a T&T Steering Column

The following is the basic order needed to reassemble a typical T&T steering column:

- 1). (1969-76) Bolt the cover adapter #60 to the mast jacket #63 with three screws #51. Install plastic bowl cover #59 onto the adapter. Rotate the cover to snap it into the slots in the adapter.
(1977-82) Position spring on key release lever into shroud slot. Compress spring by forcing with lever. With spring compressed, lever will slip into shroud. Assemble key release shroud to jacket.
- 2). (1969-76) Rework key on shift tube #66 and install shift tube through lower end of column jacket. Align key on shift tube to keyway in the boss on shift tube bowl #58. (Procedure to rework the shift tube key follows.) Install bowl so that it stops against the shoulder on the shift tube. Grease and install wave washer #56 on the shift tube extending through the bowl.
- 3). (All) Install support plate lock #55 into jacket #63.
- 4). (1969-76 only). Install flat washer #54. Install retaining ring #53 on the shift tube extending through the boss in the bowl. Grease the end of the shift tube.
- 5). Install support #49. Loctite and install four screws to hold support to lock plate.
- 6). Install complete steering shaft from upper end. (Complete procedures for checking length, lubrication, and checking tilt lash discussed previously.)
- 7). Grease the groove in the support, then guide the ignition switch actuator rod #38 down through the bowl and into the support groove. The grease will hold it in place.
- 8). Feed turn signal switch connector and wires through the turn signal housing #15, then through the bearing housing #24, and finally through the opening in the bowl. (Turn signal housing #15 and bearing housing #24 will now hang on the turn signal wires like beads on a string.)
- 9). Install the bearing housing per following instructions and install pivot pins.

Basic Order to Reassemble a T&T Steering Column (continued)

- 10). Install sight shield(s) #20 (all) and #19 (69-76 only).
- 11). Attach the turn signal switch housing to the bearing housing with three screws #12.
- 12). Attach the spring clip #14 to the key warning buzzer #13 and insert the assembly into the turn signal housing.
- 13). Pull the turn signal switch wires and install the switch with three screws #6.

(1969-76) Reattach Shift Tube to Bowl

Once that you have the two apart you now are faced with reattaching them without damaging the shift tube. Unless you have a special tool to grab the inside of the shift tube and pull it into the bowl, here is a very good alternate method.

The press fit of the shift tube to the bowl is located at the raised key (part of the shift tube neck.) Carefully file the sides of the key so that you eliminate the interference and convert the attachment to a very close tolerance slip fit. You can then assemble the tube to the bowl by hand. You want the tube to slide easily through the bowl until the shoulder on the shift tube stops against the bowl.

Install Support Lock Plate

(1969-76) Grease and install wave washer #56 on the end of the shift tube #66. Slide the support plate lock #55 onto the shift tube.

(All) Work the plate lock into notches in mast jacket #63 by tipping the plate lock toward 12 o'clock position and into the jacket opening. Slide plate lock into notches in the mast jacket. (It will only lock into place one way.)

(1969-76) Grease and install flat washer #54. Install retaining ring #53 on the shift tube. Grease the end of the shift tube.

Install Support - Shown On Instruction Pic #3

Align the holes in the support #49 to the tapped holes in the support plate lock. You should now apply Loctite and tighten the four screws #48 sequentially in 20 in-lb increments to 88 inch-lbs max. You will need a ¼ inch socket.

If all you were intending was to tighten the bolts you don't have to disassemble everything, apply the Loctite one bolt at a time.

Reassembly – Sector, Rack, Leaf Spring, & Bolt to Bearing Housing

Install the sector shaft #26 into the bearing housing. Lightly tap the sector #34 onto the shaft far enough to expose the snap ring groove. Replace the snap ring #33 if it was removed. On later columns, lightly tap the sector onto shaft far enough to snap sector into drive shaft groove.

Install the lock bolt #22 and engage with the sector. Install the rack #37 and leaf spring #36. (Replace shim if one was removed.) The big tooth on the sector must engage the corresponding big space on the rack.

Install Ignition Switch Rod to Support

Grease the slot on the side of the support. Slide the rod part of the ignition switch rod #38 through the opening between the bowl and the mast jacket. Place the head with the pin pointing out in the support slot. The grease will hold it in place.

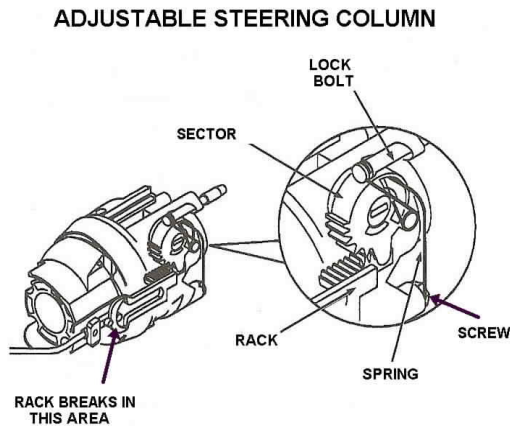

Reassembly – Lock Bolt Spring

Install one end of the lock bolt spring #23 on the lock bolt, insert middle of spring into slot in the sector, and attach other end of spring to the housing with retaining screw #32. Tighten screw to 35 inch lbs.

Reassembly – Bearing Housing to Support & Pivot Pins

Screw the tilt lever into the shoe release lever #31. While holding up the tilt lever to disengage the lock shoes, “walk” the housing assembly onto the support. **Be very careful** when you slide the housing over the steering shaft so as not to displace any bearing balls in the housing. Move the rack #37 downward (away from the driver) and hold. Tilt the housing to the left until the fan part of the rack engages the pin on the ignition switch rod. If this is a dimmer column, snake the dimmer rod through the opening in the housing at the 9:00 position.

Push the housing down until the pivot pin holes are in alignment. Release the tilt lever so that one of the lock shoes will engage the dowel pin #27.

Lubricate and install the pivot pins #35. Use palm pressure to start them. Make sure that the left pin is straddled by the rack. Use a small hammer and punch to set the pins so that they are flush with the bearing support. Verify that the column will tilt properly. Unscrew the tilt lever.

Reassembly – Tilt Spring

Place the bearing housing assembly in the full “up” position. Assemble the tilt spring #17 and spring guide #18. Apply grease between the guide and the peg on the support. Press on the tilt spring retainer #39 compressing the spring, turn the retainer clockwise to secure it in the housing (shown in the picture on page 8.)

Reassembly – Sight Shield(s)

(1969-76) The T&T column has two shields. There is a tilt lever shield A and a turn signal lever shield B. The following pictures describe the installation of the two shields.

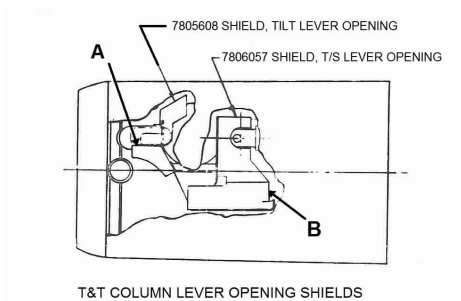
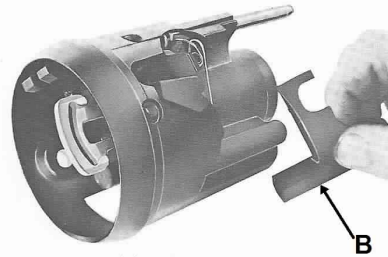
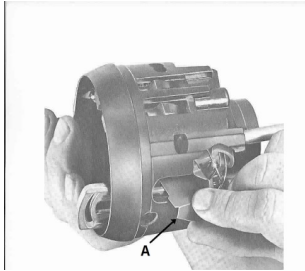

(1977-82) The T&T column has only one shield. It is the tilt lever sight shield. It attaches on the inside of the end cap that fits on the end of the lock housing cover.

Reassembly - Dimmer Pivot and Actuator

(1977-82) Install the dimmer pivot to the lock housing cover. (Early dimmer pivots were retained by a long bolt, later pivots used a press fit pin.) On 1977 columns route the wash/wipe switch wires down through the column. Assemble the plastic dimmer rod actuator to the end cap using some heavy grease. The actuator is guided between the end cap and the metal housing and is retained during assembly by the grease on the little square post inside the cap. Without the grease, the actuator is very difficult to hold in place while reassembling the column because the wire rod isn't exactly tightly fixed in position.

Reassembly – Lock Housing Cover

(All) Assemble the cover with three screws. Seat the screw at the 12 o'clock position first. Tighten the three screws to 100 in-lbs.

(1977-82) Screw in the tilt lever. Install the housing cover end cap. **Verify that the dimmer switch functions** (the rod can become disengaged from the switch) before continuing the rest of the column reassembly.

Continue with Reassembly Instructions Contained in Papers #2 and #1.

T&TColumnD&R#3Rev26DE2009.doc
JIML82@aol.com