

1969 THROUGH 1976 GM A & F-CAR TILT STEERING COLUMN DISASSEMBLY & REPAIR INSTRUCTIONS PAPER #3

Disassembly and Repair Instructions Addressed in this Paper

	Degree of Difficulty	Page
REMOVE, REPLACE, & REPAIR LOOSE PIVOT PINS	Hardest	2 & 3
REPLACE LOOSE LOCK SHOES	Hardest	4
REPLACE RACK AND SECTOR	Hardest	4
REPAIR THE UPPER BEARINGS	Hardest	4 & 5
TIGHTEN SUPPORT SCREWS	Hardest	5
REMOVE STEERING SHAFT FROM STRG COLUMN	Hardest	5 & 6
ELIMINATE LASH IN THE PLASTIC TILT JOINT	Hardest	6
REPLACE LOWER COLUMN BEARING	Moderate	7

How the Paper is Setup

This is the third of a series of three papers that address various replacement and adjustment procedures that can be performed on the GM A & F-car tilt steering column.

This paper starts at the point where the steering column has been removed from the car. Also, the steering wheel, horn parts, shaft lock, ignition lock cylinder, key warning buzzer, turn signal, ignition, and dimmer switches have been removed from the tilt steering column. All of these operations were described in detail in Papers #1 & #2.

This paper makes reference to Descriptions #5, #6, & #7. They are included on three pages of line drawings entitled Tilt Strg Column 69-76 Disassembly & Repair Pics #1, #2, & #3. Also there is a schematic drawing entitled Tilt Steering Column Blowup. Most steering column parts will be called out with a reference number from this blowup.

There is also an additional page entitled Tilt Strg Column 69-76 Parts & Installation Pics which contains drawings of the steering column attachment in the vehicle.

The drawings are all available from the author or from the host websight. You will find these pictures and descriptions to be most helpful when working on your steering column.

Types of Steering Columns Addressed in this Paper

This is a generic paper for all tilt steering columns that were installed in General Motors 1969 through 1976 A & F-car models. Some of the pages of pics do not reference the F-car. Don't worry about it, I just haven't updated the titles.

The tilt steering columns from 1969 through 1976 are called "round" columns because the column head is completely circular in shape. Starting in the late seventies, a characteristic bulge appeared on the left side of the column head. This bulge housed the headlight dimmer pivot which actuated a rod which tripped the dimmer switch now mounted on the steering column jacket down under the dash.

Disassemble the Column Head - Description #4

Unscrew and remove the tilt lever. Remove the three Torx turn signal housing screws #8 located at the 12, 3, and 8 o'clock positions.

Remove Tilt Spring - Description #5

Replace the tilt lever and place the column in the full "up" position.

Caution: The spring is quite powerful, without the steering wheel to counterbalance its force, the column head can spring upward with a lot of energy.

Remove the tilt lever spring retainer #24 using a tool that just fits into the slot opening. Note, the picture on page #6 shows a screwdriver blade being inserted into the retainer slot for removal/installation. Early retainers have a slot, later retainers have a square hole. A medium size Phillips bit will fit the square shape quite well.

Caution: The spring is compressed with a lot of force. Press squarely on the retainer and press in approximately 3/16 inch, turn 1/8 turn counterclockwise until the ears align with the grooves in the housing and remove the retainer, spring #25, and guide #26.

Remove Ignition Switch – Description #7

The ignition switch should already have been removed from the steering column jacket. Reference Paper #2; page 5.

Remove Pivot Pin - Description #5

Remove the two pivot pins #30. Each of the pins has a tapped hole so that you can use the GM tool or jury rig a puller using an 8-32 screw, nut, washer, and a 1/2 inch or a 12mm socket. Bridge each pin with the socket and use the screw and nut to pull them out. You will note that the bowl of #53 Gearshift Lever Housing comes right up to the edge of each pivot pin. You cannot react against the fragile bowl. But you also must keep your removal tool square to the pivot pins. Two home made tools that provide clearance to the bowl and keep things square are shown below. Some people have successfully threaded a screw into the pins and pried them out with a pair of pliers.

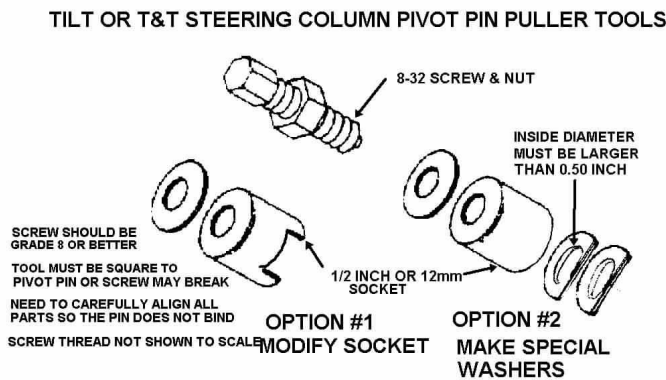

One other method to extract the pivot pins would be to thread a 8-32 screw into the end of each pin. Grip the screw with a slam puller tool. A few quick raps should draw the pin right out.

Remove Bearing Housing – Description #5

Remove the bearing housing #23 by pulling back on the tilt lever disengaging the lock shoes. Tilt the column head all the way up. Now move the housing to the right so that the rack #37 will disengage from the ignition switch rod #38. When they disengage, pull the housing up off the steering shaft assy.

Loose Pivot Pins

The pivot pin large diameter (0.4000/0.4005 inch) should be a press fit to the bearing housing #23. The pin smaller diameter (0.3745/0.3740 inch) should be a sliding fit to the support #44. The pivot pin holes in the support and in the housing as well as the diameters of the pivot pins are held to very precise tolerances.

The large diameter on the pin should be an interference fit to the housing. It should be impossible for you to insert it into the housing by hand. You will have to tap it with a hammer or press it in place with a c-clamp or other device. Once a pin is pressed in place in the housing, it should be secure with absolutely no looseness.

You should be able insert the smaller diameter of the pivot pin into the support hole. Now, thread an 8-32 screw all the way into the tapped hole in the pivot pin. Secure it in place with a jam nut. Now, try and wiggle the screw, you should not feel any motion between the pivot pin and the support. If one or both holes in the support are badly out of round or tapered, it is probably best to replace the support.

Loose Pivot Pins – Possible Corrective Actions

- 1). The pivot pins are hardened. They also have a very thin surface coating. The first thing to try is to rotate the loose pivot pin(s). It just might be possible that the surface coating on the pin may be worn in just one location so that rotating the pin to a different position and reinserting into the housing or support might regain the precision fit.
- 2). The next approach may be to replace the housing or support with one that has pivot holes of the correct size. The support #44 from any tilt or T&T column from 1969 through at least 1982 should be an acceptable replacement. However, only a tilt column with a round head can supply the bearing housing #23 for a 1969 through 76 tilt column.
- 3). The other course of action is to make the pivot pins larger. If you have access to a machine shop, you could fabricate new pivot pins from hardenable steel with a larger outside diameter to regain the press fit to the housing and/or the precision slip fit to the support. Another thing you could try is to plate the original pivot pins. After plating you will probably have to polish the appropriate diameters so as to attain the proper interference or slip fit. Remember, a press fit is only a few ten thousandths of an inch of interference between the pins and the housing holes. Any more interference and the pins will plow metal out of the mating housing holes as they are being inserted rather than just expanding the hole to lock them in place.

Loose Lock Shoes

There are two lock shoes #20 in every tilt or T&T steering column. They alternate locking the steering column tilt head one at a time. That is why if you have one bad shoe or the pin is worn where only one shoe pivots, it is possible that your column head may feel loose at every other tilt position. Both shoes pivot on a small pin #22 that is part of the housing. They engage a pin #45 that is part of the support.

Look for a worn shoe pivot pin. The shoes should rotate freely on the pin but there should be no noticeable looseness. Replace the pin and/or the shoes if needed.

DO NOT LUBRICATE THE SLOTS IN THE LOCK SHOES. They should be “dry as a bone”. It is possible that the column can be made to “ratchet” all the way to the lowest position if the slots are lubricated.

If you have access to a donor tilt or T&T steering column, you may find that the lock shoes do not have locking slots in exactly the same location as the shoes from your steering column. Tilt shoes from other adjustable columns will still fit your housing but may slightly restrict your maximum up or down tilt travel.

Remove Rack and Sector – Description #5

Remove the tilt lever opening shield #16 from the housing and also the turn signal lever opening shield if so equipped. Remove the lock bolt spring #19 by removing the spring retaining screw #27, and moving the spring clockwise to remove the lock bolt #18.

If there is a snap ring #28, remove it from the sector drive shaft #21. With a small punch lightly tap the drive shaft from the sector. Remove the drive shaft. Remove the rack #37 and rack spring #36 (also a shim, if there is one). Remove sector #29 and bolt #18.

Replace the Upper Bearings – Missing Balls/Broken Separator - Description #5

There are two bearings (#17 & #35) located in the bearing housing #23, they are seated back to back with one inch between them. They consist of an outer race, a plastic ball separator, and ball bearings. The bearing outer races are press fit into the housing, one toward the driver and the other one in the other side of the housing pointed in the opposite direction. The balls ride on inner races. One is permanently pressed onto the steering shaft yoke #39. The other inner race #11, the one closest to the driver, is a loose fit to the shaft. This one is preloaded by upper bearing inner race seat #10 that is pushed by a 100# spring #6, and secured with around wire lock plate retaining ring #3.

The column upper bearing service kit is GM part number 26001827. It contains one bearing with an inner and outer race. However, if you need both bearings, I have found that it is cheaper if you purchase GM kit #7844651. The kit contains two bearings, along with a rack, sector, lock bolt spring, and screw. Just save the extra parts or replace your thirty year old rack, sector, and spring while you have the housing apart. You should be able to purchase either kit from any GM dealer.

Replace the Upper Bearings – (Continued)

One other suggestion. One enthusiast found very similar bearings at a bicycle shop! I would guess that they were probably a lot cheaper than going through a dealership.

Now that you have the housing removed from the column, place it on a terry cloth surface. You now need to take a small screwdriver and pop the individual ball bearings out of the separator. You will soon understand why I recommended a terry cloth work surface. With all of the balls removed, it is now possible to inspect the plastic separator. If it is brittle and broken, replace it by reaching into the housing and popping the separator out of the inner race. If it is in good condition, leave it alone.

Inspect the inner race, if it is in good condition, leave it alone. Otherwise, you need to reach through the back side of the housing with a thin punch and using the notches that are in the housing bore to assist you, work the race out of the housing. Press the new inner race into place. **Caution:** Do not press the race into the housing by pushing on the balls, this will cause them to damage the race and rotation of the steering shaft will feel rough. Snap the new separator into the inner race. Individually snap the ball bearings into the separator. Make sure that you lubricate the bearing with the grease that comes in the service kit.

Caution: When you purchase replacement upper bearings you should receive the balls, a plastic separator, and the outer race as a set. It has come to my attention that the replacement bearing separator may rub on the original outer race that is pressed into the bearing housing. This will cause objectionable friction when turning the steering shaft. Snap the ball bearings into the new separator and make a trial fit to the outer race in the bearing housing. Check if the new plastic carrier rubs or not. If it rubs you will need to replace the outer race with the one supplied in the kit. Follow the instructions in the previous paragraph to remove and replace the outer race.

Tighten Support Screws - Description #7

If you have come this far, be sure to retighten the support screws listed next! If your column head hasn't loosened as yet, it still probably will in the future. (This has been a common problem.) And who wants to go through this again!

You should now locktite and tighten (88 in-lbs, 7 ft-lbs max) the four screws #43 that hold the support #44 to the support plate lock #50 and to steering column mast jacket #56. You will need a ¼ inch socket. You don't have to disassembly everything, apply the locktite one bolt at a time. Then torque them sequentially in 20 in-lb increments.

Removing Steering Shaft from Steering Column

At this point it should be fairly easy to remove the steering shaft from the steering column. First remove the detachable flange from the lower end of the steering column shaft. All Saginaw adjustable steering columns load the steering shaft from the steering wheel end of the column. So with the bearing housing removed the steering shaft should slide right up and out.

Removing Steering Shaft from Steering Column (Continued)

However, corrosion can cause this simple procedure to be quite a bit more difficult. The lower steering column bearing and the lower steering column shaft (out in the engine compartment) can be exposed to road contamination and moisture. The inner race of the lower bearing assembly is a slip fit over the lower steering shaft and this race can fuse to the shaft with rust. Therefore, you may need to soak the bearing race and shaft with a penetrant. In some cases the corrosion can be so bad as to require that you slit the bearing race with a Dremel type tool to remove the bearing.

Steering Shaft Tilt Joint Lash Check & Lash Elimination Procedure

If you have removed the steering shaft assembly from the column, here is a quick test to determine if the plastic sphere tilt joint is properly snug. Straighten the shaft assembly at the pivot ball and hold the lower steering shaft as the upper steering shaft sticks straight out. There should be sufficient friction in the plastic ball to the shaft yokes so that the upper shaft will remain straight or will just barely slump downward. If the joint is so loose that the upper shaft falls to a 90 degree angle, most likely you will have some looseness in the joint where you might detect some steering wheel play while driving.

To regain the proper amount of tightness you will need to separate the upper from the lower steering shaft. First mark the upper and lower shafts so that you can reassemble them with the correct upper to lower shaft orientation.

Separate the upper from the lower shaft by bending the upper shaft at a 90 degree angle to the lower shaft. You will now be able to pull them apart. The plastic sphere will remain in the yoke of the upper shaft. Rotate the sphere 90 degrees and it will slip out of the yoke. Note that there is a preload spring in between the two spheres.

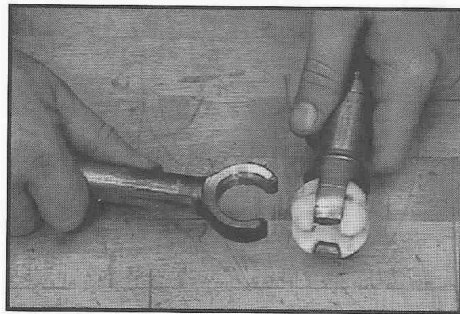

Separating Upper and Lower Shaft Sections

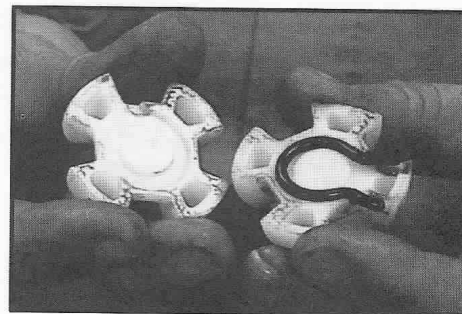

Joint Preload Spring in Centering Sphere

Lash Elimination Procedure

Now take a mallet and tap on the lower shaft yoke ears. Do not tap on them too hard! Reassemble and try the “slump test” again. Continue tapping on the yoke ears until the looseness in the ball joint is eliminated.

You can reassemble the shafts by first installing the spring in between the two spheres. Slide and rotate the spheres into the upper yoke. Position the lower shaft onto the upper yoke and rotate the lower shaft 90 degrees, making sure that the upper shaft and the lower shaft are oriented correctly.

Remove Steering Column Lower Bearing Parts

All tilt steering columns 1969 thru 1976 use the same lower end parts. All of the parts are available through GM dealers and several other suppliers.

Column Lower Bearing	GM #7805700
Column Lower Bearing Adapter (plastic)	GM #7805822
Column Lower Bearing Shield Wire Clip	GM #7804439
Column Lower Bearing Shield	GM #7804440

Pry the Lower Bearing Clip (shown on blowup but not numbered) from the column jacket with a screwdriver. Remove the stamped Lower Bearing Reinforcement #61). Pull the Lower Bearing #60 and Lower Bearing Adapter #59 from the column Mast Jacket #56.

The above procedure is very straight forward and easy AS LONG AS THE PARTS ARE NOT ALL CORRODED TOGETHER. You will need to follow the same suggestions that were outlined in removing the steering column shaft above.

The following procedures address the reassembling of the steering column.

Apply a thin coat of lithium grease to all wear surfaces **except** the lock shoe slots, lock cylinder, lock bolt, and lock bolt hole.

Reassembly – Lower Steering Column Bearing

Assemble the lower bearing to the plastic adapter. Align the tabs on the adapter to the cutout in the column mast jacket. Slide the bearing and adapter assembly up the steering column shaft and into the end of the column mast jacket. Install the lower bearing retainer with the cutout in the shield aligned with the mast jacket cutout. Install the retainer clip.

Reassembly – Sector, Rack, & Bolt

Install the drive shaft into the housing. Lightly tap the sector onto the shaft far enough to expose the snap ring groove. Replace the snap ring if it was removed. On later columns, lightly tap the sector onto shaft far enough to snap sector into drive shaft groove.

Install the lock bolt and engage with the sector. Install the rack and leaf spring. (Replace shim if one was removed.) The block tooth on the rack must engage the block tooth on the sector.

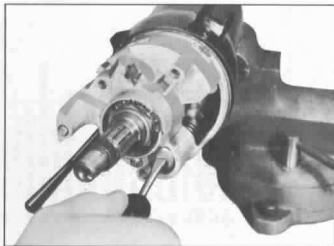

Removing Tilt Lever Spring Retainer

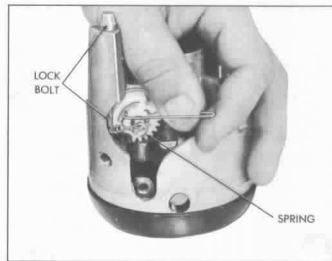

Replacing Lock Bolt Spring

Install the bolt spring and spring retaining screw. Tighten screw to 35 inch lbs. Install the ignition switch actuator rod through the shroud from top and insert in the slot in the support

Reassembly - Housing to Support & Pivot Pins

Screw the tilt lever into the shoe release lever #34. While holding up the tilt lever to disengage the lock shoes, “walk” the housing onto the support. **Be very careful** when you slide the housing over the steering shaft so as not to displace the bearings in the housing.

Move the rack downward and hold. Tip the housing to the left until the rack engages the pin on the actuator rod. Push the housing down until the pivot pin holes are in alignment. Release the tilt lever in order to lock the shoes onto the dowel pin. Remove the tilt lever.

Lubricate and install the pivot pins. Use palm pressure to start them. Make sure that the left pin is straddled by the rack. Use a small hammer and punch to set the pins so that they are flush with the bearing support. Verify that the column will tilt properly. Unscrew the tilt lever.

Reassembly – Tilt Spring

Place the housing in the full “up” position. Assemble the tilt spring #25 and spring guide #26. Apply grease between the guide and the peg on the support. Turn the tilt spring retainer #24 clockwise to secure it (shown on previous page.)

Installing Sight Shields

The 1969-76 tilt column has two shields. There is a tilt lever shield A and a turn signal lever shield B. The following pictures describe the installation of the two shields that are used in a 69-76 tilt column.

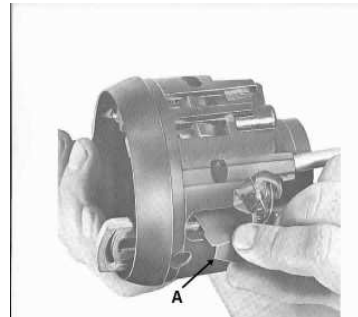
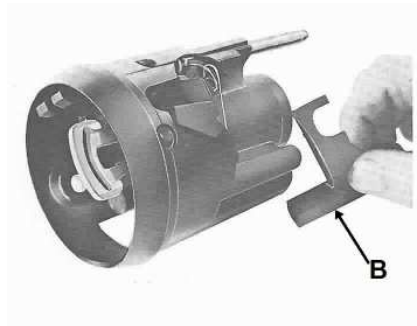

Reassembly – Lock Housing Cover

Assemble the cover with three screws. Seat the screw at the 12 o’clock position first. Tighten the three screws to 100 in-lbs. Screw in the tilt lever.

Continue with Reassembly Instructions Contained in Papers #2 and #1.

TiltColumnD&R#3-16FE2009.doc
JIML82@aol.com