

## 1969 THRU 1982 C3 CORVETTE TILT AND TELESCOPING STEERING COLUMN DISASSEMBLY & REPAIR INSTRUCTIONS PAPER #2

Disassembly and Repair Instructions Addressed in this Paper

	Degree of Difficulty	Page
DROP OR REMOVE STEERING COLUMN FROM VEHICLE	Moderate	3 & 4
REPLACE TURN SIGNAL SWITCH	Moderate	4 & 5
TURN SIGNAL SWITCH WIRE COLOR & GAGE	Moderate	4
REPLACE/ADJUST DIMMER SWITCH	Moderate	5 & 6
REPLACE/ADJUST IGNITION SWITCH	Moderate	6 & 7
REPLACE LOWER COLUMN BEARING	Moderate	7

### How the Paper is Setup

There are a limited number of steering column service procedures that are addressed in this paper. This paper starts at the point where the steering wheel, horn parts, shaft lock, ignition lock cylinder, and the key warning buzzer have been removed from the adjustable (T&T) steering column. The turn signal switch has been detached from the column housing and has been moved up and out of the way but the wiring is still routed through the column. All of these operations were described in detail in Disassembly & Repair Paper #1.

There are several reasons why you would want to drop or remove your steering column from your vehicle. First, in order to remove the turn signal switch completely from the T&T column, it is far easier to snake the wires out of the column with the steering column removed from the car. Second, in order to work on the ignition switch or the dimmer switch you will find that they are totally inaccessible unless you drop the column. Third, for other major work on the column, it is far easier to do it on a bench rather than in the car.

This paper makes reference to various line drawing descriptions. They are included on several pages entitled Corvette C3 Tilt & Telescoping Steering Column – Page #1 & #3. Also there are two schematic drawings: T&T Steering Column 69-76 Blowup Pic and Tilt Steering Column w/Key Release & Dimmer (similar to 77-82) Blowup Pic. Most steering column and installation parts will be called out with a reference numbers and letters from these drawings. The drawings are all available from the author or from the host websight.

### Types of C3 Steering Columns Addressed in this Paper

This paper addresses the 1969 through 1982, second generation, energy absorbing, function locking, C3 tilt & telescoping steering columns. It does not cover the 1968 C3, first generation, energy absorbing, telescoping only column.

A word of caution: **DISCONNECT THE BATTERY when you work on the steering column.** With the steering column partially disassembled it is possible to inadvertently move the ignition switch to the start position.

## General Information

There are two different designs of steering column mounted ignition switches. The standard (non adjustable) steering column ignition switch works in the opposite direction from the T&T steering column switch. Although either switch will connect to your vehicle wiring harness, the switches are not interchangeable. So if you are replacing your ignition switch, make sure that you obtain the correct replacement part.

The headlight dimmer switch was mounted on the floor and was foot actuated from 1969 through 1976. The switch was moved to the steering column on all C3 Corvettes in 1977 and was actuated by the turn signal lever. The switch remained on the steering column through 1982.

On 1969 through 1976 Corvette columns there is a lever on the lower end of the steering column (out under the hood, just under the brake booster.) It is connected to a cable that attaches to the transmission. On cars with automatic transmissions, the cable pushes the column lever to the full Up position when the transmission is shifted into Park. With manual transmissions, it pushes the column lever full Up when the transmission is shifted into Reverse.

All 1977 through 1982 Corvettes have a small key release lever next to the ignition lock cylinder on the steering column that the driver has to trip in order to be able to rotate the ignition key to the Off-Lock position. This later design does not require a back drive cable. This key release column requires that you install the ignition switch and lock cylinder differently than the older steering columns.

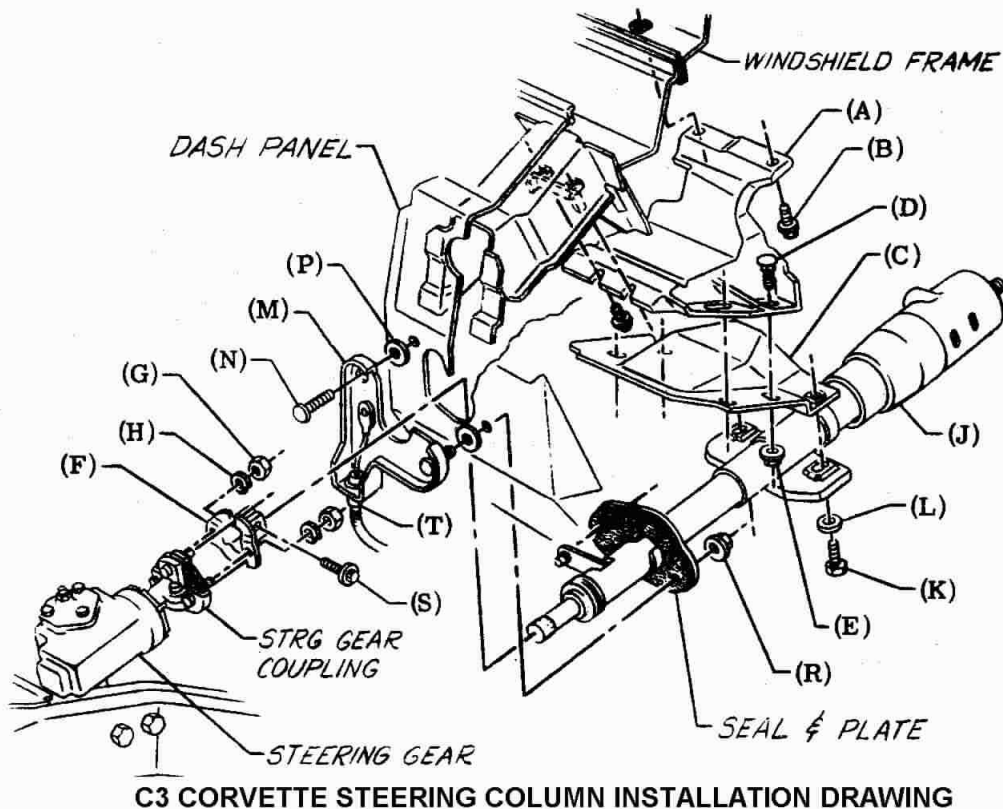

## **Instructions for Dropping and Removing the Column**

First of all, **NEVER** just remove the two vertical screws that hold the steering column up into the dash and let the column “hang” by the attachments at the flexible coupling and the two fasteners coming through the dash panel. Letting the column “hang” in that manner puts very high loads on the steering column lower bearing and can cause it to fail.

Second of all, disconnect the battery before working on the steering column.

If your C3 has a steering column back drive system (all 1969 through 1976 models), you will need to open the hood and look directly under the brake booster. There will be a lever on the lower end of the steering column with a cable attached to it. Remove the cotter pin and washer, disconnect the back drive cable from the pin on the lever. There is also a metal lower column plate (M) attached to the dash panel. The cable sheath is attached to the plate. You can leave the cable attached to the plate. This plate also holds a welded stud and a loose carriage bolt (N) that secures the lower end of the column (J).

If you have a manual transmission, you will find a fairly heavy clutch pedal return spring attached to the plate and to the Z-bar. You should detach one end of the spring at this time. **Hint!** Detach the clutch pedal push rod from the Z-bar. This will allow the Z-bar to rotate rearward and take some tension off the spring.

Next, remove the two nuts (G) and lockwashers (H) that connect the flexible coupling to the steering column flange (F).

Go back inside the car and remove the plastic closeout panel from under the steering column. Remove the crossover bar and the air conditioning duct that passes under the steering column. Remove the two nuts (R) that attach the steering column to the outside lower column plate. Now go back under the hood and pull the plate away from the dash. You will also find that there are two washers (P) sandwiched between the plate and the dash panel.

Now, go back inside and unfasten the two vertical screws (K) and washers (L) that hold the column up into the dash.

Make sure on 1976 and earlier columns that you have the back drive lever all the way in the Up position and that it is aligned with the cutout in the front of dash. Now pull the column straight back, disconnecting the column flange from the two flexible coupling bolts. (You may need an assistant out under the hood to help disengage the parts.) Pull back and rotate the steering column so that it will drop and rest on your front seat.

You can now disconnect the two body harness electrical connectors from the column ignition switch. There are three plastic tabs that need to be depressed in order to disengage them from the switch. Disconnect the turn signal “harmonica” electrical connector from the vehicle wiring. Disconnect the electrical connector(s) from the dimmer switch and the cruise control wires (if so equipped). The steering column can now be removed from the car.

**CAUTION:** There is a locking rod (approximately 4 inches long x 0.218 inch dia) down inside the upper steering shaft. Without the “star” screw in place, the rod can just fall out as the column is removed from the car. The rod can go unnoticed and you won’t know why your telescoping feature will no longer lock when you reassemble the column.

**Removing the Turn Signal Switch – Description #2**

I have a T&T column and I have found it much easier to remove the turn signal switch when the steering column is out of the car. This allows much easier access to the switch wiring and being able to “fish” the harmonica electrical connector up through the column.

Begin by wrapping the edge of the plastic turn signal switch connector and the wires that lead back into the column with tape to keep them in a line. This will help prevent the connector from cocking and snagging as you pull the turn signal switch wires up through the column. You want the tape to form a very smooth “bullet” nose between the connector and the wiring. However, you do not want the tape to be very thick! Clearances are extremely tight coming up through a T&T column!!

**Helpful Hint!** Tie a piece of light but strong wire or some twine to the connector to be used as a tracer wire to help during reassembly. Adjustable columns - place the tilt head in the straight position. **Caution!** Without the steering wheel to counterbalance the tilt spring, the column head can quite violently snap up when you release it with the tilt lever. Place the lower column back drive lever in the full Down position. Now, pull the switch straight out, guiding the wiring harness and connector out at the same time. Leave the tracer wire or twine in the column so that you can tie it to the new signal switch connector and help direct the wiring back down through the column.

**Alternate Method of Feeding Switch Wires Through the Column**

Some people have been successful using the following procedure; disengage and remove the individual switch wires and metal contacts from the plastic “harmonica” connector. Straighten a heavy paper clip or use a very thin blade screwdriver. Insert it into the “harmonica” connector from the contact side to disengage each wire and contact. There should be a small molded square channel in the connector that will guide you to a metal tang on the contact that holds it in place. Once you depress the tang and pop the wire and contact out of the connector, you should take a small knife blade and bend the tang back out so that it will engage the connector correctly upon reinstallation. The turn signal switch wiring can now be fed separately through the column.

YEARS	WIRE COLOR AND GAGE	CONNECTOR POSITION
1969-82	White 18 gage	P
1969-82	Dark Green 18 gage	N
1969-82	Yellow 18 gage	M
1969-82	Purple 18 gage	L
1969-82	Brown 18 gage	K
1969-82	Dark Blue 18 gage	J
1969-82	Light Blue 18 gage	H
1969-82	Black 18 gage	G
1969-82	Light Green 20 gage	F
1969-82	Tan 20 gage	E
1980, 81, & 82	Black 18 gage	C
1980, 81, & 82	Orange 18 gage	B
1980, 81, & 82	Brown 18 gage	A

### **Feeding Switch Wires Through the Column (Continued)**

Make sure that you reinstall your switch wires into the “harmonica” connector in the correct order, so that when you reassemble them, all your lights, horn, and buzzers will work correctly.

If all you wanted to do was replace the turn signal switch, the installation procedure follows directly.

If you are continuing to disassemble the column you will need to remove the ignition and dimmer switches from the column and then proceed to Disassembly & Repair Paper #3.

### **Reinstalling the Turn Signal Switch**

Adjust the tilt head so that it is straight and the back drive lever all the way Down. Pull the wiring down through the housing with the aid of the tracer wire. Be sure it feeds under the mounting bracket. If the column is out of the car, you might find that feeding the wires and connector is easier if someone holds the column vertical. You will note that the cavity inside the column for the wires to feed extends from about the 4 to 5 o'clock positions. Have the connector at 5 o'clock and the wires at 4 o'clock. Use the tracer wire and push down on the connector with a long, thin screwdriver.

Please return to Corvette C3 T&T Column Disassembly and Repair Paper #1, page #6 to complete the installation of the turn signal switch into the column. The reinstallation procedure for the entire steering column into the vehicle follows at the end of this paper.

### **Replace/Adjust Dimmer and/or Ignition Switches**

In order to gain access to the ignition switch and/or the dimmer switch, the steering column must be dropped down from the dash or removed from the car entirely. It is best to first remove the steering wheel since the column will not drop very far because the steering wheel rim hits the car seat. The various types of C3 steering wheels and their removal are discussed quite thoroughly in Paper #1.

### **General Information**

As mentioned previously in this paper, there are two different ignition switches. The standard (non-adjustable) steering column ignition switch works in the opposite direction from the T&T or tilt steering column switch. In other words, the standard column actuates the switch with a rod that pushes down on the switch to move it into the Start position. The adjustable column pulls up on a rod to move its ignition switch to the Start position. Either switch will connect to your vehicle wiring harness. However, you will need to twist the three connectors on your vehicle wiring harness 180 degrees to convert from the switch on a standard (non-adjustable) steering column to the switch on a T&T column.

The headlight dimmer switch was mounted on the floor from 1969 through 1976. It was placed on the steering column in 1977 and continued through 1982.

### **Removing the Dimmer Switch**

The lower dimmer switch attachment (closest to the floor) is with a nut. The nut threads onto a stud. The lower half of the stud holds the ignition switch in place. If you are not going to work on the ignition switch make sure that you only remove the nut and do NOT loosen the stud otherwise you will have to adjust the ignition switch as well. Now remove the screw on the upper part (steering wheel side) of the switch. You can now disengage the dimmer switch from the actuator rod and remove it.

### **Installing and Adjusting the Dimmer Switch**

#### **T&T Column Description #7**

Insert the dimmer rod into the switch. Loosely install the screw in the upper attaching hole and snug the nut on the stud. Depress the switch slightly and insert a 3/32" drill into the switch as shown in Description #7 to remove lash. Tighten the screw and nut to 35 in-lbs. Remove the drill and check the dimmer switch function by actuating the turn signal lever. You should hear a sharp snap.

### **Removing the Ignition Switch**

On cars equipped with column mounted dimmer switches, the dimmer switch will have to be removed first and then the ignition switch. Follow the above procedures to remove the dimmer switch.

Remove the ignition switch from the column by removing two screws (or a stud and a screw). Pull the switch off the column actuator rod. You may need to twist the switch 90 degrees to get it off the actuator rod. If further disassembly of the column is necessary, please download paper #3 and continue your repairs.

### **Installing and Adjusting the Ignition Switch –**

#### **T&T Column Description #7**

In order to correctly install the ignition switch it is necessary for the lock cylinder to be installed in the column and placed in the Off-Unlock position.

#### **Back Drive Columns (1969-1976)**

First, reach down to the lower column lever and move it all the way down to its lowest position. Now rotate the lock cylinder all the way counterclockwise until it stops. The lock cylinder is now in Off-Unlock position.

#### **Key Release Columns (1977-1982)**

Rotate the lock cylinder all the way counterclockwise until it stops. DO NOT actuate the key release lever. This will place the lock cylinder in the Off-Unlock position.

You now need to place the ignition switch in that same Off-Unlock position. You do this by moving the slider all the way to the end of travel to the Accessory position. It should detent and stay in that position. If in doubt, the other extreme will be the Start position and you will feel a spring return. Now move the slider two detent positions back from the Accessory position, this will be the Off-Unlock position.

### Installing and Adjusting the Ignition Switch (Continued)

Fit the actuator rod into the slider hole and assemble it to the column with the two fasteners. Lightly push the switch down the column (away from the steering wheel), to take out lash in the actuator rod, and tighten the mounting screws. Caution should be exercised to prevent moving the switch out of the Off Unlock detent. Tighten the fasteners to 35 in-lbs.

Reinstall and readjust the dimmer switch if so equipped.

### Remove/Replace Steering Column Lower Bearing

All C3 steering columns 1969 thru 1982 use the same lower end parts. All of the parts are available through GM dealers, Zip Products, and several other suppliers.

Column Lower Bearing	GM #7805700	Zip SC-442
Column Lower Bearing Adapter (plastic)	GM #7805822	Zip SC-452
Column Lower Bearing Shield Wire Clip	GM #7804439	Zip SC-453
Column Lower Bearing Shield	GM #7804440	Zip SC-454

Pry the lower bearing wire clip from the column jacket with a screwdriver. Remove the stamped lower bearing shield (retainer). Pull the lower bearing and plastic lower bearing adapter from the column mast jacket.



Remove clip.  
Lower lever on 1969-76  
columns only.

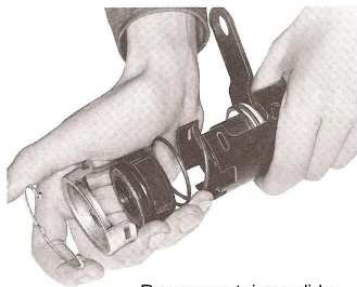

Remove retainer, slide  
lower bearing adapter out of  
steering column jacket.

The above procedure is very straight forward and easy AS LONG AS THE PARTS ARE NOT ALL CORRODED TOGETHER. If you find a lot of corrosion on your lower column parts, it is a good idea to soak them in penetrating oil for a day or two before trying to remove them.

### Reassembly – Lower Steering Column Bearing

Assemble the lower bearing to the plastic adapter. Align the tabs on the adapter to the cutout in the column mast jacket. Slide the bearing and adapter assembly up the steering column shaft and into the end of the column mast jacket. Install the lower bearing shield with the cutout in the shield aligned with the mast jacket cutout. Install the retainer clip.

**Note: T&T steering columns do not have a coil spring behind the bearing adapter.**

### **Reinstalling the Steering Column into the Vehicle**

Move the lower column lever back to the up position. Carefully slide the column back through the dash hole. Insert the column flange onto the two flexible coupling bolts (the bolts are different sizes so the flange will only go on one way.) Tighten the nuts and lockwashers to 20 ft-lbs.

Reconnect the electrical connectors to the ignition switch, turn signal switch, dimmer switch, and cruise control (if so equipped).

Some people have reported that when they replaced their turn signal switch they found that the “harmonica” connector from the new switch would not snap correctly onto the vehicle wiring connector. The problem can easily be corrected by swapping your original connector onto wires from the new switch. Instructions were included earlier on page #3 to remove and reinstall the wires.

Snug but do not tighten the column in place with the two vertical screws up under the dash. Go back under the hood and loosely install the lower column plate with its stud and washer onto the dash panel. Also insert the carriage bolt into the plate, assemble the washer to the bolt, and assemble the plate, bolt, and washer to the dash panel. Now check the alignment of the flexible coupling pins in the column flange slots. They should be central. You may need to move the lower column and outside plate around in order to make the pins central. Then go back inside the car and reattach the nuts to the welded stud and carriage bolt and torque to 10 ft-lbs. Rotate the steering wheel 90 degrees and again visually check if the flexible coupling pins are central in the flange slots. Loosen the two plate fastener nuts and readjust the column as necessary. Torque the two vertical column screws to 15 ft-lbs.

Reattach the AC duct, the crossover bar, and plastic closeout panel under the steering column.

(If so equipped), place the lower column lever in the full UP position, reattach the transmission backdrive cable (manual transmission in Reverse, automatic in Park). Fasten the cable to the pin on the lower lever with the washer and cotter pin.

**Refer to Disassembly & Repair Paper #1 for reinstalling the shaft lock, steering wheel and horn parts.**

T&TColumnD&R#2Rev26JA2009  
[JIML82@aol.com](mailto:JIML82@aol.com)