

1967 and 1968 CORVETTE TELESCOPING STEERING COLUMN DISASSEMBLY & REPAIR INSTRUCTIONS - PAPER #1

Disassembly and Repair Instructions Addressed in this Paper

	Difficulty	Page
REMOVE STRG WHEEL AND HORN PARTS	Easy	2
REMOVE TURN SIGNAL LEVER	Easy	2
REPLACE THE TURN SIGNAL SWITCH	Moderate	3 & 4
REPLACE OR REPAIR UPPER COLUMN BEARING	Moderate	4 & 5
ADJUST TELESCOPE LOCK	Easy	6

How the Paper is Setup

This is the first of two papers that address various replacement and repair procedures that can be performed on 1967-1968 Corvette first generation, energy absorbing, telescoping (adjustable), steering columns. All of the service procedures outlined in this paper should be fairly easy and accomplished without removing the steering column from the car. The next paper (Disassembly & Repair Paper #2) addresses removing the steering column from the car and replacing the lower bearing (a somewhat more complex operation.)

The 1967 start of production (SOP) telescoping Corvette columns were part of the General Motors steering shaft recalls. Since the 1967 Chevrolet Chassis Repair Manual was already in print, it does not show or discuss any of the new parts required by the recall. Unfortunately, the 1968 manual was updated in a somewhat haphazard manner and is not entirely correct either. Since the early 1967 steering columns should all have been recalled and updated, I will not address the early steering shafts, adjusters, or lower bearings.

1967 and 1968 Steering Columns

Even though the 1968 Corvette had an all new exterior and interior, the chassis remained the same as the 1967 model. For these reasons the 1967 Corvette telescoping steering column is similar but not identical to the 1968 Corvette column. The large mounting bracket #9 (with the three aluminum mounting capsules) is welded in place and is quite different between the two years. Also the 1968 steering column has a welded toe plate bracket on the lower end of the steering column. The 1967 column was clamped to a bracket that was part of the dash plate. Therefore, the columns will not interchange.

It is not necessary to remove the steering column from the vehicle in order to work on the components in the upper end. Such things as the steering wheel, telescope lock, horn parts, turn signal switch, and the upper steering shaft bearing can all be removed and serviced in-car and are discussed in this D&R Paper #1.

A Word of Caution Before Beginning Work On Your Steering Column
DISCONNECT THE BATTERY.

Remove Horn Button, Telescope Lock, Steering Wheel, and Hub

Carefully reach under the horn button cap assembly #1 with a small screwdriver and pry the cap from the horn contact #6. 1967-68 cap assemblies consist of three pieces that are all staked together. At this time, you might want to check the underside of the cap assembly to make sure that the three stakes are secure. You may even want to add some JB Weld to the stakes for insurance.

Remove three screws #2 securing horn contact #6, shim #5, and spacer #8 to steering wheel hub assembly #13. Remove two small screws #3 and remove star screw #4 and locking lever #7. If needed the steering wheel #10 can now be detached from the hub assembly by removing six screws #9,

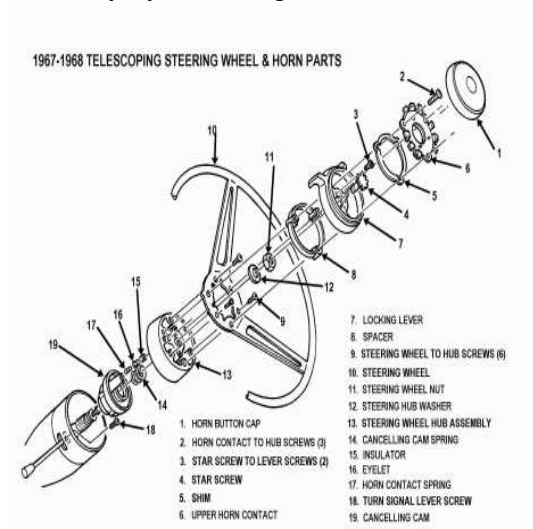

Remove the steering wheel nut #11 and the hub washer #12. You should be able to see a small indentation on the steering wheel hub assembly and a similar indentation on the very end of the steering column shaft. The two marks should be aligned.

These marks will allow the hub to be properly indexed to the spines on the column shaft when you reassemble them. If you can't find the markings, use a crayon or chalk to make your own marks on the steering wheel hub and the end of the steering column shaft.

Next, using a steering wheel puller, remove the steering wheel #10 and hub assembly. Make sure that your puller and bolts are square to the hub as you turn the large bolt and apply force. I also place a heavy washer on the end of the steering shaft so that the large puller bolt does not distort the threads on the end of the shaft. Never hammer on the end of the steering shaft.

You can now remove the large spring #14 and the canceling cam #19. There should be a spring loaded plunger (called eyelet #16) that protrudes from the tower on the canceling cam. You should be able to freely depress the eyelet against the small spring #17 inside the tower. Insulator #15 holds them in place. It can now be removed to access the eyelet and spring if these parts are to be inspected or replaced.

Removing Turn Signal Lever

You can now access the screw #18 that retains the turn signal lever to the turn signal switch. You now have full access to the turn signal switch.

Note: All component part numbers on the next several pages refer to parts that are shown on the Steering Column Blowup at the end of this paper.

1967 Only - Remove the Turn Signal Switch & Wires

Go down under the dash and disconnect the curved turn signal switch connector from the vehicle body harness. The 1967 steering column has a part called an escutcheon #7 installed on the steering column jacket. It serves to close the gap between the instrument cluster and the steering column. Detach the two plastic covers from the column head by removing two screws. Remove the two screws that attach the escutcheon to the dash.

If your goal is to remove the steering column from the car and/or replace the lower bearing, it is suggested that at this point you skip to D&R paper #2.

Loosen the three vertical screws that attach the steering column up into the dash so that it can be lowered down about one quarter inch. This will disengage the stud on the top of the escutcheon from the instrument cluster. You will now be able to pull it up toward the steering wheel. **Warning! Never let the steering column “hang” without support.**

You will now have access to remove the metal turn signal switch wiring protector #1 by removing the two screws #2 and unsnapping it from the jacket. The turn signal switch wires pass through a narrow gap between the escutcheon and the column jacket.

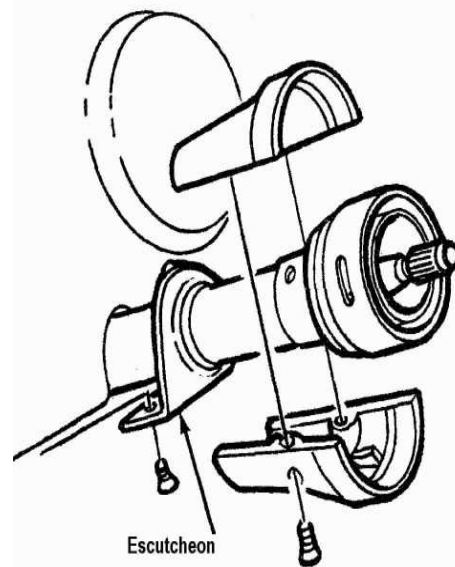

1967 CORVETTE STEERING COLUMN COVERS

However, the curved plastic electrical connector is too large to pass through the gap. So if you need to remove or replace the turn signal switch, you will need to remove the wires from the connector and pull them through the escutcheon a few at a time.



Make sure that you make note of the wire positions before you remove them from the connector. Straighten a heavy paper clip or use a very thin blade screwdriver; insert it into the connector from the contact side to disengage each wire and contact. Once you pop the wire and contact out of the connector, you should take a small knife blade and bend the tang back out so that it will engage the connector correctly upon reinstallation.

1968 Only - Remove Turn Signal Switch & Wires

Go down under the dash and disconnect the curved turn signal switch connector from the body harness. In order to gain access to metal trough #1 that protects the wiring you will need to remove the covers and closeout panel that surrounds the steering column. Remove the fasteners and the four plastic covers that enclose the upper end of the steering column. Remove the four fasteners and the closeout panel that is underneath the column.

If your goal is to remove the steering column from the car and/or replace the lower bearing, it is suggested that you skip to D&R paper #2.

Remove the two screws #2 on the sides of the steering column jacket that hold the metal turn signal wiring protector #1 in place. Unsnap the protector from the mast jacket. The wires are now free to pass up and through the bearing housing #5 and the signal switch cover #6.

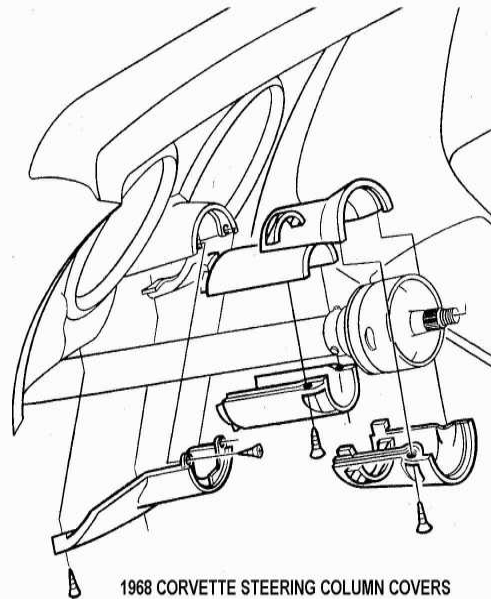

ALL - Removing the Turn Signal Switch

Push in the hazard warning knob and remove the knob and screw. Remove three turn signal switch screws #3. Pull the switch and wires straight out of the switch cover. Note that the 1967 turn signal switch wires will have the curved plastic connector removed. The 1968 switch can be removed with the connector in place.

ALL - Remove the Bearing Housing, and Switch Cover

Remove the spiral retaining ring #26 from the steering shaft.

Then remove the thrust washer #27 and the wave washer #28. Remove turn signal switch screws #3. Slide the signal switch cover #6 and upper bearing housing #5 off of the steering column.

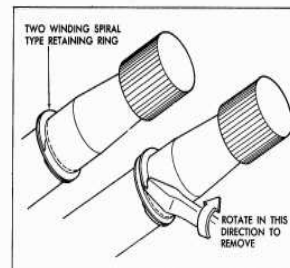

Replace or Repair Upper Column Bearing

The bearing that is part of the housing was not designed to be serviced. It was a press fit into the housing and there was a thin lip on the housing bore that was staked or spun over to retain the bearing. The bearing has been known to come loose. If this is the problem that you are correcting, you can try to epoxy glue the bearing case into the housing bore. You can also attempt to carefully peen limited areas of the case over on the bearing.

Replace or Repair Upper Column Bearing (Continued)

You can also purchase a bearing or bearing housing assembly from suppliers such as:

Corvette Steering Service

www.corvettesteering.com (864)-287-9990

The bearing and bearing housing are shown as being available but no part numbers are provided on the websight.

Doc Rebuild

www.docrebuild.com 1-800-866-9362

67-68 Upper Bearing Only 6521108

67-68 Upper Bearing Housing (Used) 6521145

Turn Signal Switch, & Bearing Housing Reassembly

Assemble the upper bearing housing #5 and turn signal switch #4 into the cover #6. On the 1967 column pass the turn signal switch wires through the escutcheon #7. Assemble the parts over steering shaft #20. Secure parts to the upper tube and flange #8 with three screws #3 tighten to 30 inch-lbs.

Slide wave washer #28, thrust washer #27, and spiral retaining ring #26 onto steering shaft. Press parts together and seat retaining ring into groove in steering shaft. Make sure that the retaining ring is fully seated.

Place the turn signal lever into the slot in the turn signal switch and attach with correct screw, tighten to 20 inch-lbs. Screw hazard warning knob in place, torque to 4 inch-lbs.

Pull signal switch wires flat to mast jacket and assemble metal wiring protector trough to jacket and secure with screws #2. Torque screws to 22 inch-lbs. 1967 column reattach the curved turn signal switch connector to the wires. Reconnect the turn signal switch connector to vehicle body harness.

Reassemble Covers and Canceling Cam and Hub

Note: From this point onward please refer to the steering wheel drawing on page 2.

Assemble plastic covers and escutcheon (1967) or covers and closeout panel (1968). Place the canceling cam #19, the large spring #14, and the steering wheel hub assembly #13 on the steering shaft. The horn tower on the canceling cam (with the eyelet, spring, and retainer) fits through the hole in the hub. Align the mark on the hub to the mark on the end of the steering shaft. Assemble washer #12 and steering hub nut #11. Torque nut to 35 ft-lbs.

Install Steering Wheel

Attach the steering wheel to the hub with six screws #3. It is suggested that you loctite these screws since they have a tendency to loosen. Torque to 20 inch-lbs. The 6 o'clock spoke on the steering wheel should be opposite the mark on the end of the steering shaft.

Adjust Telescope Locking Lever

Place the spacer #8 on the steering wheel hub assembly. Set the telescope locking lever #7 on top of the spacer (with the steering wheel straight ahead, the finger tab part of the lever should be in the 12 o'clock quadrant). Thread the special "star" screw #4 into the end of the steering shaft. Now, use a phillips screwdriver to tighten the "star" screw until you can no longer telescope the steering shaft. Place the finger part of the locking lever at about the 1 o'clock position. Secure the locking lever to the "star" screw in that position with the two small screws #3. Torque them to 30 inch-lbs. You can now test the effort required to lock and unlock the telescope feature. Readjust the locking lever to suit your preference.

Reassembly of Upper Horn Contacts

Place the shim(s) #5 and the upper horn contact #6 on the spacer. Attach the horn contact to the hub with three screws #2. Torque to 19 inch-lbs. Make sure that the eyelet plunger #16 sticking up through the hub touches the horn contact. Snap on the horn cap #1.

Reconnect the battery.

You are done!!!

Final Words of Caution:

To maintain the energy absorbing function of the steering column, always replace screws, bolts, and nuts with identical fasteners as specified.

If a steering column assembly is removed from the car, special care must be taken as you handle it. A sharp blow on the end of the steering shaft, leaning on the column, or dropping the column could shear the plastic fasteners inside the column which maintain steering shaft and column rigidity. Remember, plastic parts that are over 25 years old can be very brittle! Handle your steering column parts with care.

Never allow the steering column to just "hang" under the dash by only the floor pan connections and the flexible coupling. This places very high stresses on the lower column bearing and the mast jacket itself. Always have someone hold the column; block it up; or wire it in place if you must remove the vertical bolts that hold it into the dash.

JIML82@aol.com

67-68TeleColumnD&R#1Rev09JA2009

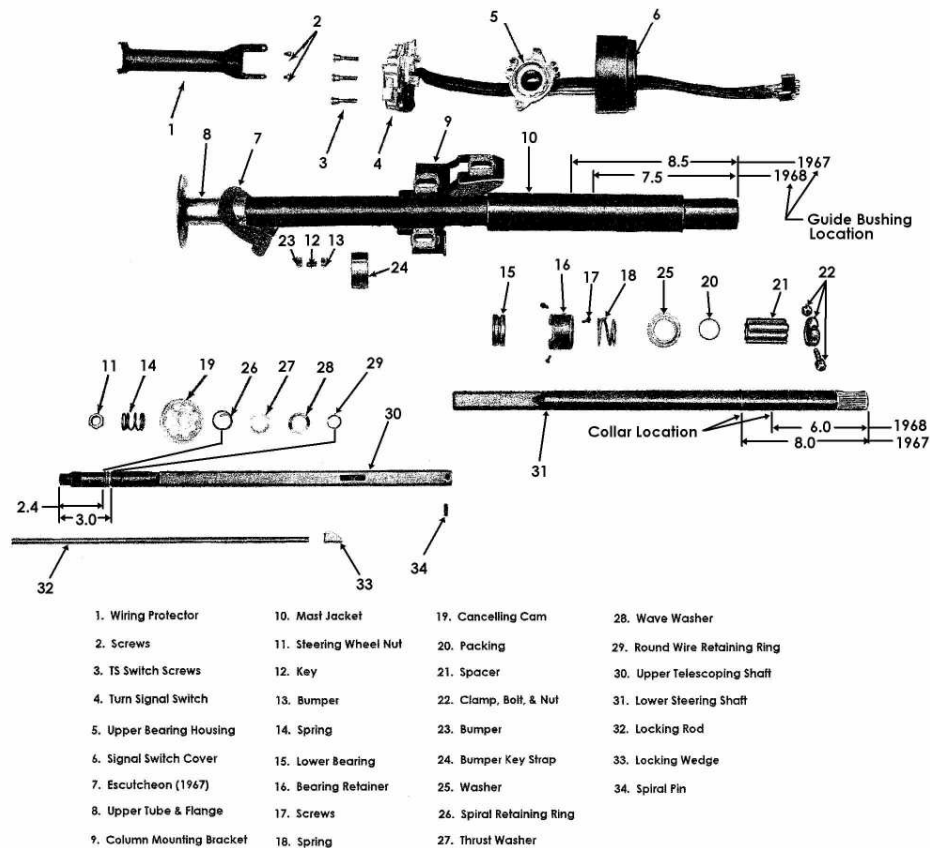

1967 (Late) Corvette Telescoping Steering Column Blowup

1968 Telescoping Steering Column Similar

I have compared the telescoping steering column blowup pictures in the 1967 & 1968 Chevrolet Chassis Repair Manuals versus the steering column engineering drawings for those years. For the most part, neither of the manuals reflect the engineering drawings accurately. I have updated the blowup drawing in the following areas:

- 1). There is a round wire retaining ring #29 on the upper telescoping shaft #30 that is not called out in the original blowups. It is installed in a groove that is located 3.0 inches from the steering wheel end of the shaft. That ring is GM #5694191 and is available through GM dealers, numerous Corvette suppliers, or at salvage yards.
- 2). There is also a spiral pin #34 that is pressed into the other end of that shaft. It prevents the telescoping shaft from pulling out from the lower shaft #31.
- 3). The lower bearing package shown in the 1967 manual is completely wrong. Parts shown in the 1968 manual are misidentified. Lower bearing parts (#15, 16, 17, 18, 20, 21, 22, & 25) shown in my blowup now match the engineering drawings.
- 4). There is a small collar that is permanently assembled on the lower steering shaft that seats the lower bearing. It is not serviceable but its location differs from 1967 to 1968.
- 5). There is a plastic steering shaft guide bushing inside the steering column mast jacket #10. It should not need servicing. Its location differs from 1967 to 1968.